



Manual

EtherCAT F/T Interface



Document #: 9620-05-EtherCAT

Engineered Products for Robotic Productivity

Pinnacle Park • 1031 Goodworth Drive • Apex, NC 27539 USA • Tel: +1.919.772.0115 • Fax: +1.919.772.8259 • www.ati-ia.com • Email: info@ati-ia.com

Foreword

Information contained in this document is the property of ATI Industrial Automation, Inc. and shall not be reproduced in whole or in part without prior written approval of ATI Industrial Automation, Inc. The information herein is subject to change without notice and should not be construed as a commitment of ATI Industrial Automation, Inc. This manual is periodically revised to reflect and incorporate changes made to the F/T system.

ATI Industrial Automation, Inc. assumes no responsibility for any errors or omissions in this document.

Copyright © by ATI Industrial Automation, Inc., Apex, North Carolina USA. All Rights Reserved. Published in the USA.

In consideration that ATI Industrial Automation, Inc. (ATI) products are intended for use with robotic and/or automated machines, ATI does not recommend the use of its products for applications wherein failure or malfunction of an ATI component or system threatens life or makes injury probable. Anyone who uses or incorporates ATI components within any potentially life-threatening system must obtain ATI's prior consent based upon assurance to ATI that a malfunction of ATI's component does not pose direct or indirect threat of injury or death, and (even if such consent is given) shall indemnify ATI from any claim, loss, liability, and related expenses arising from any injury or death resulting from use of ATI components.

All trademarks belong to their respective owners.

Windows™ is a registered trademark of Microsoft Corporation.

Note

Please read the manual before calling customer service. Before calling, have the following information available:

1. Serial number (e.g., FT01234)
2. Transducer model (e.g., Nano17, Gamma, Theta, etc.)
3. Calibration (e.g., US-15-50, SI-65-6, etc.)
4. Accurate and complete description of the question or problem
5. Computer and software information. Operating system, PC type, drivers, application software, and other relevant information about your configuration.

If possible, be near the F/T system when calling.

How to Reach Us

Sale, Service and Information about ATI products:

ATI Industrial Automation

1031 Goodworth Drive
Apex, NC 27539 USA

www.ati-ia.com

Tel: +1.919.772.0115

Fax: +1.919.772.8259

E-mail: info@ati-ia.com

Technical support and questions:

Application Engineering

Tel: +1.919.772.0115, Option 2, Option 2

Fax: +1.919.772.8259

E-mail: ft_support@ati-ia.com

Table of Contents

1. Safety	6
1.1 Explanation of Notifications	6
1.2 General Safety Guidelines	6
1.3 Safety Precautions	6
2. Product Overview	7
2.1 LED Functions	7
2.1.1 EtherCAT Link/Activity LED.....	7
2.1.2 Run LED.....	8
2.1.3 Sensor status LED.....	8
3. Installation	9
3.1 Providing Power to the EtherCAT Sensor	9
3.1.1 Providing Power Using PoE.....	9
3.1.2 Providing Power Using External Power.....	10
3.2 EtherCAT Connector 4-Pin M12	10
3.3 Optional Power Connector 3-Pin M8	11
3.4 Optional Earth Ground Connection	11
4. Operation	12
4.1 Sample Rate	12
4.2 Filtering	12
4.3 Threshold Monitoring	12
4.4 Tool Transformation	12
5. EtherCAT Bus Interface	14
5.1 PDO Interface	14
5.2 EtherCAT Dictionary Objects (SDO Data)	14
5.2.1 Object 0x2020: Tool Transformation.....	14
5.2.2 Object 0x2040: Calibration.....	15
5.2.3 Object 0x2060: Monitor Condition.....	17
5.2.4 Object 0x2080: Diagnostic Readings.....	17
5.2.5 Object 0x2090: Version.....	18
5.2.6 Object 0x6000: Reading Data.....	18
5.2.7 Object 0x6010: Status Code.....	19
5.2.8 Object 0x6020: Sample Counter.....	20
5.2.9 Object 0x7010: Control Codes.....	20
6. Troubleshooting	21
6.1 Errors with Force and Torque Readings	21

- 7. Specifications 22**
 - 7.1 Storage and Operating Conditions..... 22**
 - 7.2 Electrical Specifications 22**
 - 7.3 Weights and Dimensions..... 22**
- 8. Drawings 23**
- 9. Terms and Conditions of Sale..... 25**

Glossary of Terms

Term	Definition
CoE	CANopen over EtherCAT, the preferred embedded protocol for configuring EtherCAT devices. Used within SDO to encode the configuration data.
DINT	A data type representing an unsigned integer with 32 bits.
EtherCAT	An industrial automation fieldbus.
FoE	File access over EtherCAT, the preferred embedded protocol for uploading new firmware to EtherCAT devices.
F/T	Force/Torque.
F/T Transducer	Converts force and torque into an electrical signal.
MAP	The Mounting Adapter Plate (MAP) is the transducer plate that attaches to the fixed surface or robot arm.
PDO	Process Data Object, a protocol for reading and writing real-time process information cyclically.
PoE	Power-over-Ethernet, is a method of delivering electrical power to a PoE-compatible Ethernet device through the Ethernet cable. This simplifies installation of the Ethernet device since a separate power supply is not needed. The EtherCAT F/T system is PoE compatible.
SDO	Service Data Object, a protocol for reading and writing configuration information acyclically.
STG	Strain Gage
TAP	Tool Adapter Plate (TAP) is the transducer surface that attaches to the load to be measured.
Transducer	Transducer is the component that converts the sensed load into electrical signals.
UDINT	A data type representing an unsigned integer with 32 bits.
UINT	A data type representing an unsigned integer with 16 bits.
USINT	A data type representing an unsigned integer with 8 bits.

1. Safety

The safety section describes general safety guidelines to be followed with this product, explanation of the notification found in this manual, and safety precaution that apply to the product. More specific notification are imbedded within the sections of the manual where they apply.

1.1 Explanation of Notifications

The notifications included here are specific to the product(s) covered by this manual. It is expected that the user heed all notifications from the robot manufacturer and/or the manufacturers of other components used in the installation.



DANGER: Notification of information or instructions that if not followed will result in death or serious injury. The notification provides information about the nature of the hazardous situation, the consequences of not avoiding the hazard, and the method for avoiding the situation.



WARNING: Notification of information or instructions that if not followed could result in death or serious injury. The notification provides information about the nature of the hazardous situation, the consequences of not avoiding the hazard, and the method for avoiding the situation.



CAUTION: Notification of information or instructions that if not followed could result in moderate injury or will cause damage to equipment. The notification provides information about the nature of the hazardous situation, the consequences of not avoiding the hazard, and the method for avoiding the situation.

NOTICE: Notification of specific information or instructions about maintaining, operating, installation, or setup of the product that if not followed could result in damage to equipment. The notification can emphasize but is not limited to specific grease types, good operating practices, or maintenance tips.

1.2 General Safety Guidelines

The customer should verify that the transducer selected is rated for maximum loads and moments expected during operation. Refer to F/T Transducer Manual (9620-05-Transducer Section—Installation and Operation Manual) found in EtherCAT F/T Installation and Operation Manual (9610-05-1022) or contact ATI Industrial Automation for assistance. Particular attention should be paid to dynamic loads caused by robot acceleration and deceleration. These forces can be many times the value of static forces in high acceleration or deceleration situations.

1.3 Safety Precautions



CAUTION: Do not remove any fasteners or disassemble transducers without a removable mounting adapter plate. These include Nano, Mini, IP-rated, and some Omega transducers. This will cause irreparable damage to the transducer and void the warranty. Leave all fasteners in place and do not disassemble the transducer.



CAUTION: Do not probe any openings in the transducer. This will damage the instrumentation.



CAUTION: Do not exert excessive force on the transducer. The transducer is a sensitive instrument and can be damaged by applying force exceeding the single-axis overload values of the transducer and cause irreparable damage. Small Nano and Mini transducers can easily be overloaded during installation. Refer to the F/T Transducer manual (9620-05-Transducer Section) for specific transducer overload values.

2. Product Overview

The EtherCAT F/T sensor system measures six components of force and torque (Fx, Fy, Fz, Tx, Ty, Tz) and seamlessly streams data to devices that use EtherCAT fieldbus. Integrated signal conditioning, data acquisition, and a 1-port EtherCAT interface are all contained in a small rugged enclosure. The EtherCAT F/T also supports PoE (Power-over-Ethernet) and only requires one 4-pin, M12 connector for EtherCAT and power. No additional interface box is needed.

Power to the Transducer can be supplied from PoE through the 4-Pin M12 connector or using the external DC power connector, see [Figure 2.1](#). ATI sensors with EtherCAT interface provide the following features:

- Resolved force and torque data with an update rate of 1 kHz.
- Adjustable Digital low-pass filters
- Up to 16 different calibrations (measurement ranges) can be stored and selected using the EtherCAT interface, refer to [Section 5.2.2—Object 0x2040: Calibration](#).
- Tool transformation programmable over EtherCAT, refer to [Section 5.2.1—Object 0x2020: Tool Transformation](#) and [Section 4.4—Tool Transformation](#) for more information.
- LED indicator for Run, EtherCAT Link, and Transducer Status. Refer to [Section 2.1—LED Functions](#) for more information.

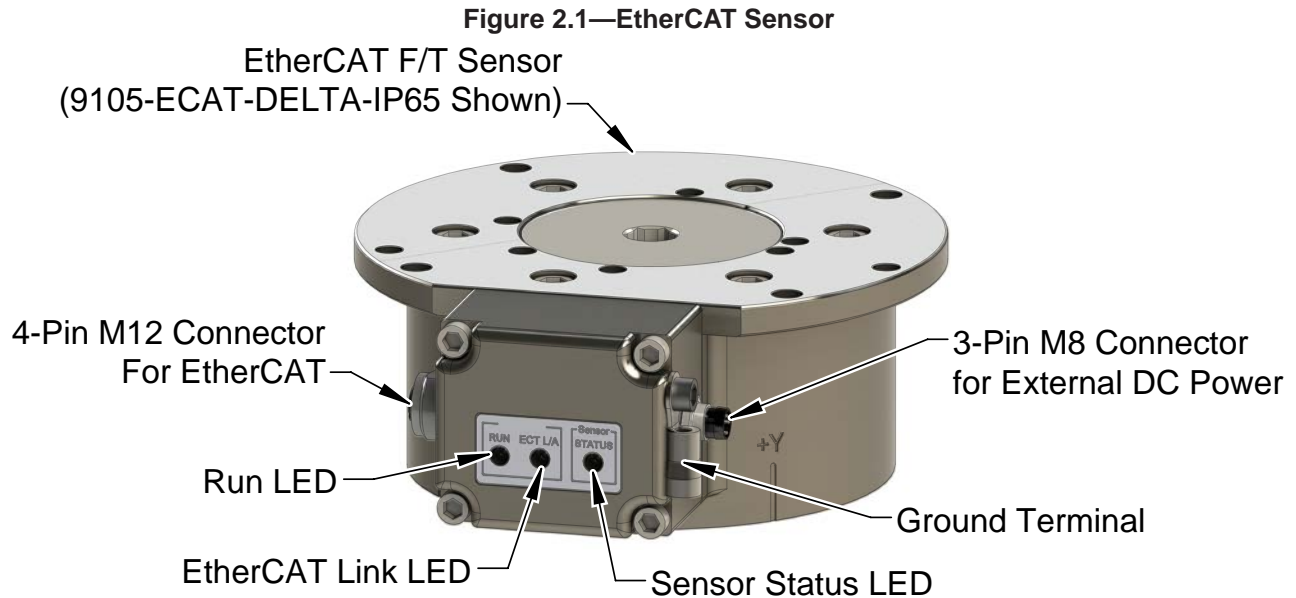

2.1 LED Functions

The EtherCAT F/T provides LEDs for EtherCAT Link, Run, and Sensor Status.

2.1.1 EtherCAT Link/Activity LED

One green LED signals activity on the EtherCAT port.

LED State	Link	Activity	Condition
Off	No	No	Port closed
Green	Yes	No	Port open
Flashing Green	Yes	Yes	Port open

2.1.2 Run LED

One green LED signals the status of the EtherCAT sensor interface in the following way.

LED State	Description
OFF	Device is in state INIT
Flashing Green	Device is in state pre-operational
Green	Device is in state operational

2.1.3 Sensor status LED

One red LED signals the status of the Sensor in the following way.

LED State	Description
OFF	No errors; the status byte is zero
Red	The status byte is non-zero; a diagnostic error occurred or a monitoring threshold is breached

3. Installation

The following section provides information for installing the EtherCAT F/T Sensor into an application. The installation of the transducer to the robot or other device is covered in the (9620-05-Transducer Section-Installation and Operation Manual).

3.1 Providing Power to the EtherCAT Sensor

The EtherCAT F/T sensor accepts power through PoE (Power over Ethernet) or from a DC power source with an output voltage range of 20V to 48V.

3.1.1 Providing Power Using PoE

The EtherCAT F/T's PoE input is compatible with the IEEE 802.3af (Power-over-Ethernet) specification and uses Mode A to receive power. Mode B requires eight Ethernet conductors and is not supported.

The EtherCAT F/T system requires a customer supplied PoE injector similar to a TP-Link® model TL-POE150S, which provides PoE on a RJ45 receptacles. Refer to [Figure 3.1](#).

1. Plug in the PoE injectors external AC power supply.
2. Connect the PoE injector to its external AC power supply.
3. Connect the PoE injector to your Ethernet network.
4. Connect the EtherCAT cable RJ45 connector to the RJ45 connector on the PoE injector and to the M12 connector on the EtherCAT sensor.

NOTICE: Refer to 9620-05-Transducer Section - Installation and Operation manual for proper cable routing and bending radius information.

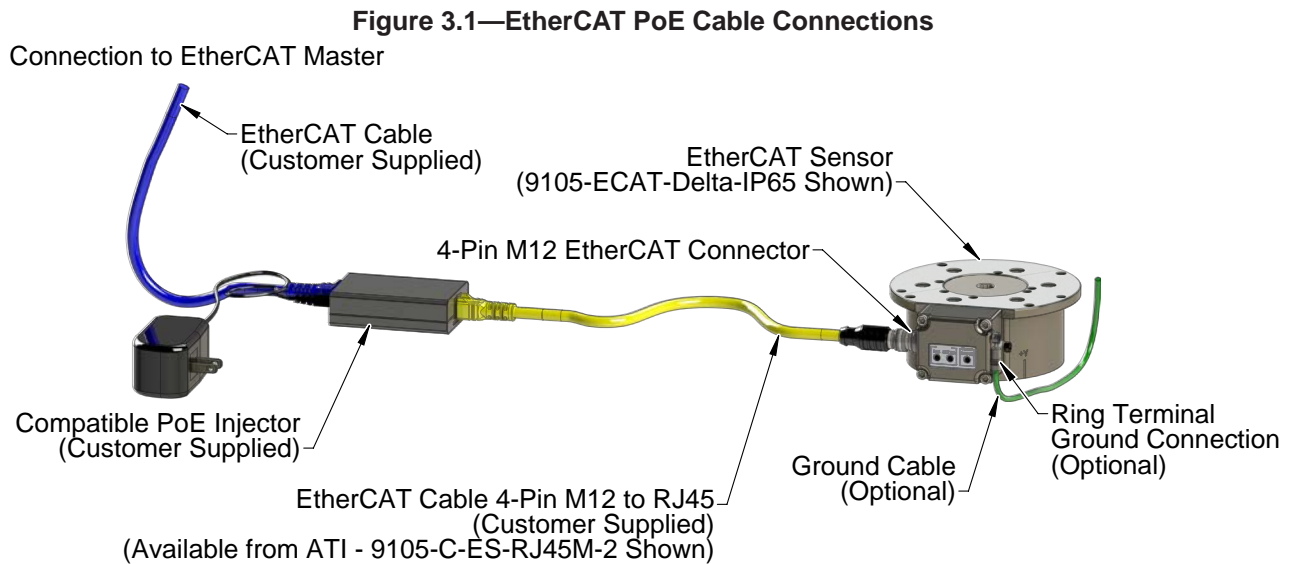

3.1.2 Providing Power Using External Power

The EtherCAT Sensor can also be powered by 20V to 48V DC power input to the 3-Pin M8 external power connector.

1. Connect the EtherCAT cable RJ45 connector to a network connection and to the M12 connector on the EtherCAT sensor.
2. Connect the external power cable to the 3-Pin M8 connector on the EtherCAT Sensor.

NOTICE: Refer to 9620-05-Transducer Section - Installation and Operation manual for proper cable routing and bending radius information.

Figure 3.2—EtherCAT External Power Cable Connections

Connection to EtherCAT Master

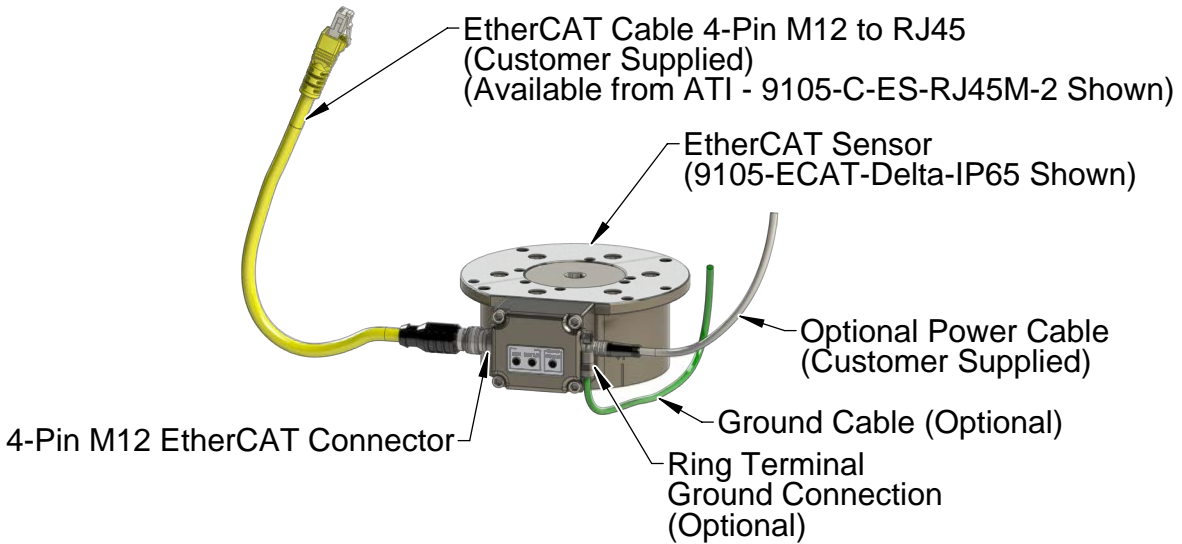

3.2 EtherCAT Connector 4-Pin M12

The 4-Pin M12 connector provides the EtherCAT connection.

Table 3.1—4-Pin M12 EtherCAT Connector	
Pin	Signal
1	TX+
2	RX+
3	TX-
4	RX-
Shell	connector block housing

Figure 3.3—EtherCAT Connector

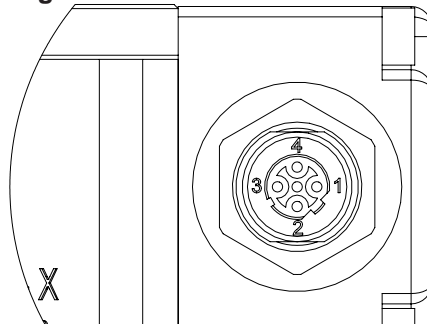

3.3 Optional Power Connector 3-Pin M8

A 3-Pin M8 connector is provided on the EtherCAT sensor to support an external power source if PoE is not being used.

Table 3.2—3-Pin M8 External Power Connector	
Pin	Signal Description
1	V+ (20V to 48VDC)
3	GND
4	Not Connected

Figure 3.4—External Power Connector and Optional Earth ground Connection

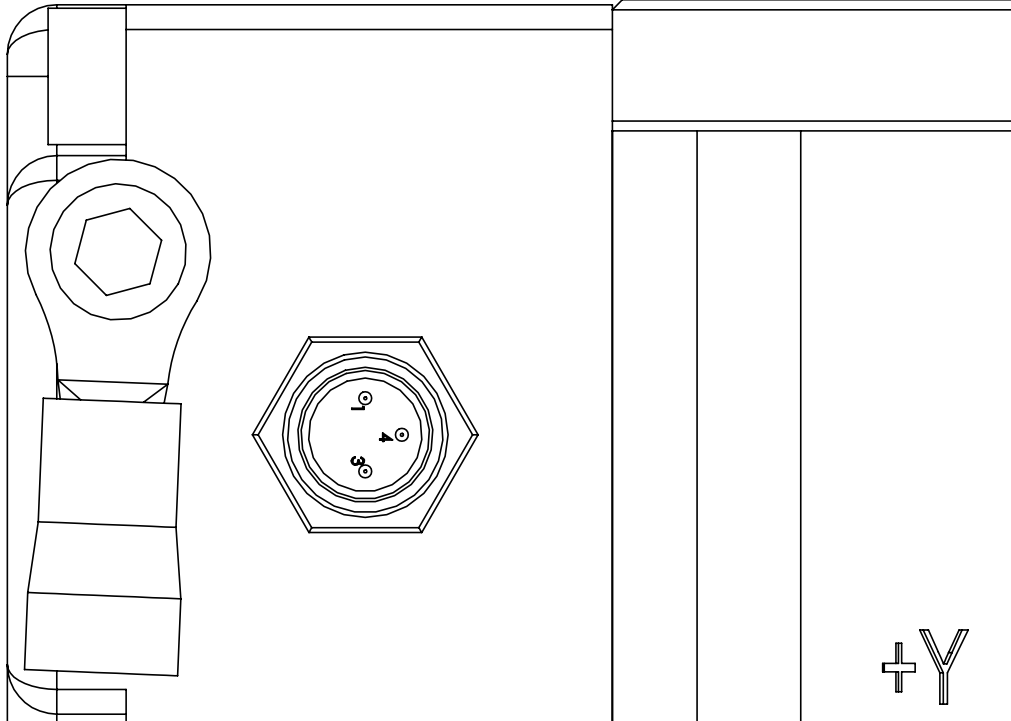

3.4 Optional Earth Ground Connection

An optional earth ground connection is provided on the EtherCAT Sensor. Typically the sensor is grounded through its connection to the robot or other device. If there is not a good ground connection through the robot or other device and noise issues interfere with the sensor readings, the optional earth ground connection can be used to improve the ground connection.

4. Operation

The following section provides information required when using software to operate the EtherCAT Sensor. Communicating with the EtherCAT sensor requires knowledge of EtherCAT standards and operation.

4.1 Sample Rate

The firmware samples internally at 3000 Hz.

4.2 Filtering

The “Filter Selection” field in [Section 5.2.9—Object 0x7010: Control Codes](#) controls the coefficient used in the internal IIR filter. The cutoff frequency is dependent on the internal sample rate, which is defined in [Section 4.1—Sample Rate](#). The relative cutoff frequencies for different values of this coefficient are:

Coefficient	Cutoff Frequency (Percent of Internal Sample Rate)	Frequency
0	No filter	N/A
1	11.97%	360 Hz
2	4.66%	140 Hz
3	2.17%	64 Hz
4	1.04%	32 Hz
5	0.51%	16 Hz
6	0.26%	8 Hz
7	0.12%	4 Hz
8	0.07%	2 Hz

4.3 Threshold Monitoring

The EtherCAT FT system allows the user to configure thresholds. To activate a threshold, first write the appropriate values from [Section 5.2.3—Object 0x2060: Monitor Condition](#), then set the bit corresponding to that threshold in the “Monitor Condition Enable Bitmap” in [Section 5.2.9—Object 0x7010: Control Codes](#).

The software currently supports one monitor condition.

4.4 Tool Transformation

To activate a tool transformation, first write the appropriate transform coefficients from [Section 5.2.1—Object 0x2020: Tool Transformation](#), then set the “Tool Transform Index Selection” bits in [Section 5.2.9—Object 0x7010: Control Codes](#) to activate that condition. The software supports one tool transformation.

The tool transformation allows you to enter a series of tool transformations in order to measure the forces and torques acting at a point other than the origin of the sensor. The tool transformations are applied in the order you enter them, so you can determine, for example, if rotations occur before displacements by entering a tool transformation with only rotations before the rotation with displacements. If you specify both rotations and displacements within a particular tool transformation, displacements are performed first, in the order DX, DY, DZ, then rotations are performed, in the order RX, RY, RZ.

- Displacement DX, DY, and DZ: The displacement along each axis is measured in the distance component of the calibration’s torque units, so if your sensor was calibrated to use Newton-meters as the torque unit, the displacement is measured in meters.
- Rotations RX, RY, and RZ: The rotation about each axis, in radians.

Displacement allows the customer to move the sensing reference frame origin along the X, Y, and Z axes.

Displacement should be calculated and values should be entered before rotation. Displacement is measured in units which are set as either Nm or in-lbs.

Figure 4.1—Displacement of Sensing Reference Frame Origin

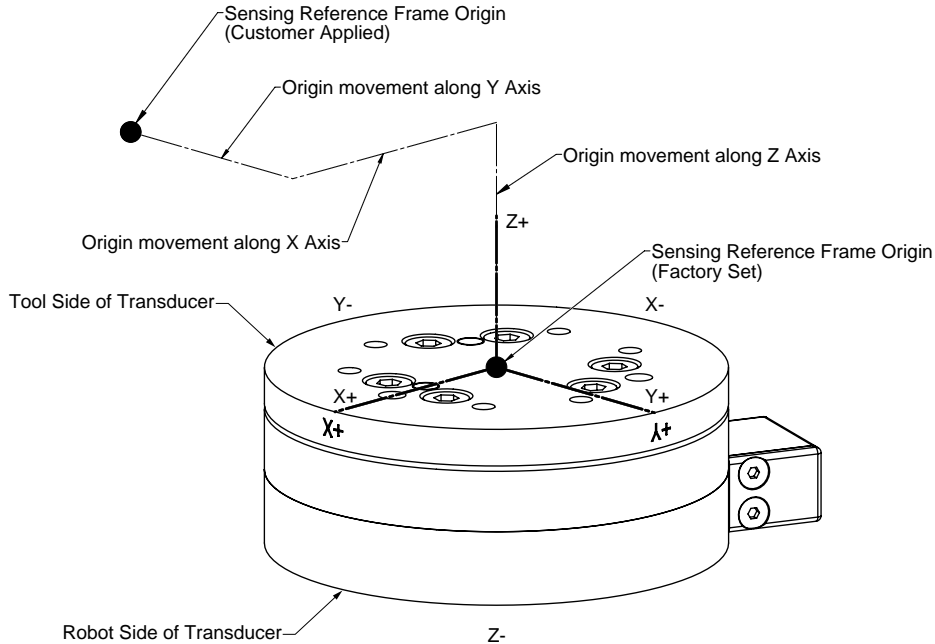

Rotation allows the customer to rotate the axes while maintaining the frame origin. *Figure 4.2* shows the direction of rotation about the axis. Rotation is measured in radians.

When a value is entered for RX, RY, or RZ the following will result:

- RX value will rotate Y and Z about X in the direction shown (see *Figure 4.2*).
- RY value will rotate X and Z about Y in the direction shown.
- RZ value will rotate X and Y about Z in the direction shown.

In a tool transformation, the order of the rotations matters. The X-rotation occurs first, followed by rotation about Y (in its new orientation), then Z. Therefore, you **MUST** express your rotations in this order.

Figure 4.2—Rotating Reference Frame

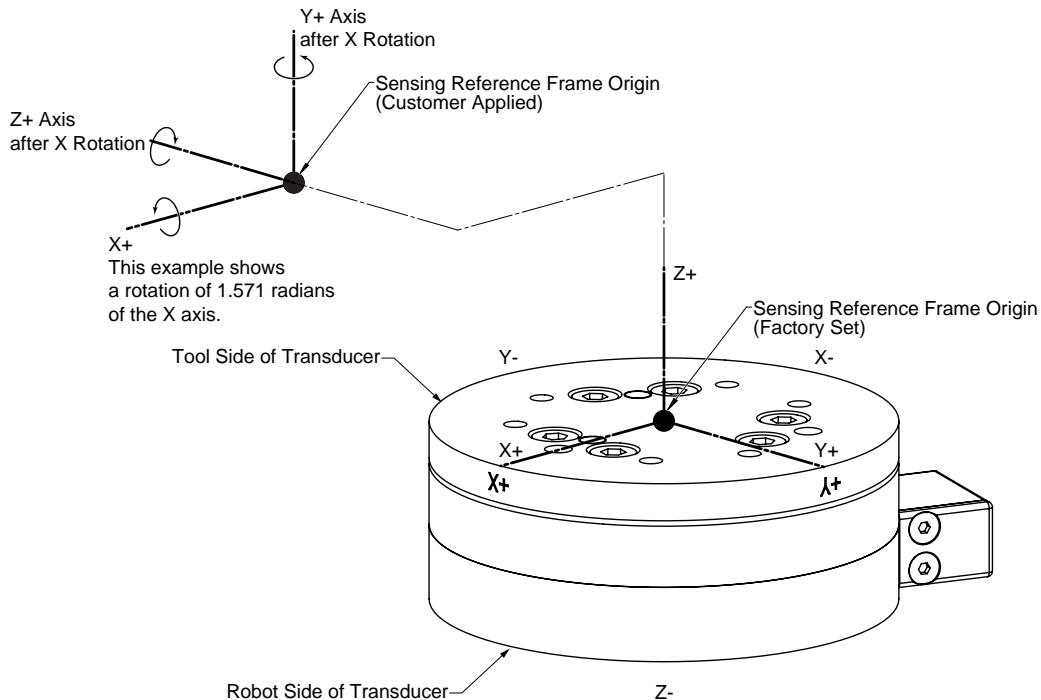

5. EtherCAT Bus Interface

The EtherCAT bus interface allows a user to:

- Determine which calibration is active
- Select a calibration to be active
- Read the active calibration information matrix, serial number, etc.
- Read the firmware revision
- Read force/torque data
- Read strain gage data and status information.
- Configure tool transformation.
- Set monitor conditions
- Set low pass filter cutoff frequency.
- Bias transducer.

5.1 PDO Interface

The PDO interface is used to exchange data in real-time with the F/T sensor.

- a. TxPDO Map / Output Data
 The TxPDO combines *Object 0x6000: Reading Data*, *Object 0x6010: Status Code*, and *Object 0x6020: Sample Counter*.
- b. RxPDO Map / Input Data
 The RxPDO map consists of *Object 0x7010: Control Codes*.

5.2 EtherCAT Dictionary Objects (SDO Data)

The SDO data is used to configure the sensor, read manufacturing, and calibration information. This section documents dictionary objects that are specific to the EtherCAT F/T sensor application; it does not list objects which are a required part of the EtherCAT standard.

5.2.1 Object 0x2020: Tool Transformation

This writable object contains the following 32-bit signed integer fields:

Table 5.1—Tool Transformation		
Subindex	Name	Description
0x01	Rx	The rotation about the X axis, in units of 0.1 degrees, e.g. an Rx value of 900 = 90 degrees.
0x02	Ry	The rotation about the Y axis, in units of 0.1 degrees.
0x03	Rz	The rotation about the Z axis, in units of 0.1 degrees.
0x04	Dx	The displacement along the x axis, in units of 0.01 calibration length units. E.g. if the distance component of the torque is meters, a Dx value of 100 = 1 meter.
0x05	Dy	The displacement along the y axis, in units of 0.01 calibration length units.
0x06	Dz	The displacement along the z axis, in units of 0.01 calibration length units.

5.2.2 Object 0x2040: Calibration

This read-only object contains information about the currently active calibration selected by the “Calibration Selection” field in [Section 5.2.9—Object 0x7010: Control Codes](#). It contains the following fields:

Table 5.2—Calibration			
Subindex	Name	Type	Description
0x01	FT Serial	STRING(8)	The FT Serial Number, e.g. “FT01234.”
0x02	Calibration Part Number	STRING(30)	The calibration part number e.g. “SI-120-95.”
0x03	Calibration Family	STRING(8)	Always reads “ECAT”
0x04	Calibration Time	STRING(30)	The date the sensor was calibrated
0x05	Matrix FxG0	DINT	These 36 elements contain the scaled “working” matrix used for this calibration. This will not necessarily match the calibration matrix in the calibration file, because the calibration matrix has to be scaled to suitably large integers before it can be used by the sensor.
0x06	Matrix FxG1		
0x07	Matrix FxG2		
0x08	Matrix FxG3		
0x09	Matrix FxG4		
0x0a	Matrix FxG5		
0x0b	Matrix FyG0		
0x0c	Matrix FyG1		
0x0d	Matrix FyG2		
0x0e	Matrix FyG3		
0x0f	Matrix FyG4		
0x10	Matrix FyG5		
0x11	Matrix FzG0		
0x12	Matrix FzG1		
0x13	Matrix FzG2		
0x14	Matrix FzG3		
0x15	Matrix FzG4		
0x16	Matrix FzG5		
0x17	Matrix TxG0		
0x18	Matrix TxG1		
0x19	Matrix TxG2		
0x1a	Matrix TxG3		
0x1b	Matrix TxG4		
0x1c	Matrix TxG5		
0x1d	Matrix TyG0		
0x1e	Matrix TyG1		
0x1f	Matrix TyG2		
0x20	Matrix TyG3		
0x21	Matrix TyG4		
0x22	Matrix TyG5		
0x23	Matrix TzG0		
0x24	Matrix TyG1		
0x25	Matrix TyG2		
0x26	Matrix TyG3		
0x27	Matrix TyG4		
0x28	Matrix TyG5		

Table 5.2—Calibration				
Subindex	Name	Type	Description	
0x29	Force Units	USINT	Value	Unit
			1	Lbf
			2	N
			3	Klbf
			4	kN
			5	Kg
0x2a	Torque Units	USINT	Value	Unit
			1	Lbf-in
			2	Lbf-ft
			3	N-m
			4	N-mm
			5	Kg-cm
6	kN-m			
0x2b	Max Fx Counts	DINT	The maximum rated value for this axis, in counts. ¹	
0x2c	Max Fy Counts			
0x2d	Max Fz Counts			
0x2e	Max Tx Counts			
0x2f	Max Ty Counts			
0x30	Max Tz Counts			
0x31	Counts Per Force	DINT	The calibration counts per force unit.	
0x32	Counts Per Torque	DINT	The calibration counts per torque unit.	
0x33	Gain G0	UINT16	The code used to program the gain potentiometer	
0x34	Gain G1			
0x35	Gain G2			
0x36	Gain G3			
0x37	Gain G4			
0x38	Gain G5			
0x39	Offset G0	UINT16	The code used to program the offset DAC.	
0x3a	Offset G1			
0x3b	Offset G2			
0x3c	Offset G3			
0x3d	Offset G4			
0x3e	Offset G5			

5.2.3 Object 0x2060: Monitor Condition

This user-writable object allows the user to configure an axis, a threshold value, and direction to continuously evaluate against the current F/T data. When an enabled condition becomes true, the monitor output becomes active and stays active until reset via setting the “Reset Monitor Condition” bit in [Section 5.2.9—Object 0x7010: Control Codes](#), which is also mapped into the TxPDO data.

The following fields are available in the monitor condition:

Subindex	Name	Type	Description	
0x01	Threshold Value	DINT	The threshold value to compare against, in counts.	
0x02	Axis	USINT	Value	
			0x03	Axis
			1	Fx
			2	Fy
			3	Fz
			4	Tx
5	Ty			
6	Tz			
0x03	CompareGreaterThan	BOOL	If TRUE, the monitor condition is true when the selected axis is greater than the selected threshold value. If FALSE, the monitor condition is true when the selected axis is less than the selected threshold value.	

5.2.4 Object 0x2080: Diagnostic Readings

This read-only object provides access to diagnostic values. These values may be useful when troubleshooting the system.

The following fields are available in the Diagnostic Readings object:

Subindex	Name	Type	Description	Limits	Sampling Rate
0x01	6V Supply Sense	UINT16	The 6V supply ADC reading.	2568 to 3970 counts	½ strain gage sampling rate. ¹
0x02	Thermistor	UINT16	The thermistor ADC reading.	None, information only.	½ strain gage sample rate. ¹
0x03	VBridge Volts	INT16	The excitation voltage ADC reading.	17050 to 17750 counts.	Strain gage sampling rate. ¹
0x04	VBridge Current	INT16	The excitation current ADC reading.	500 to 6554 counts.	Strain gage sampling rate. ¹
Note:					
1. See Section 4.1—Sample Rate for strain gage sampling rate.					

5.2.5 Object 0x2090: Version

This read-only object provides firmware version information.

The following fields are available in the version object:

Table 5.5—Version			
Subindex	Name	Type	Description
0x01	Major	UINT16	Major Version
0x02	Minor	UINT16	Minor Version
0x03	Revision	UINT16	Revision

5.2.6 Object 0x6000: Reading Data

This read-only object represents the current force/torque or gage data. It is mapped into the TxPDO input data.

The following fields are present in the reading data:

Table 5.6—Reading Data			
Subindex	Name	Type	Description
0x01	Fx/Gage0	DINT	If the “Gage Data” bit in Section 5.2.9—Object 0x7010: Control Codes is set, these fields contain the 16-bit gage data. If the “Gage Data” bit is cleared, these fields contain the 32-bit F/T result data, in counts.
0x02	Fy/Gage1		
0x03	Fz/Gage2		
0x04	Tx/Gage3		
0x05	Ty/Gage4		
0x06	Tz/Gage5		

5.2.7 Object 0x6010: Status Code

This object contains a single DINT value (at subindex 0), with the following bitmap:

Table 5.7—Status Code		
Bit Number	Description	Indicates Error?
0	Monitor Condition Tripped: This bit becomes active when an active monitor condition becomes true, and remains set until cleared with the “Reset Monitor Conditions” bit in Section 5.2.9—Object 0x7010: Control Codes .	No
1	Supply Out of Range: This bit becomes active if the supply sense reading in Section 5.2.4—Object 0x2080: Diagnostic Readings is out of the expected range. This bit remains set until power cycle. It may indicate a system fault.	Yes
2	Reserved	
3	VBridge Volts Out of Range: This bit is set if the excitation voltage in Section 5.2.4—Object 0x2080: Diagnostic Readings is out of the expected range. This bit remains set until power cycle. It may indicate a system fault.	Yes
4	VBridge Current Out of Range: This bit is set if the excitation current in Section 5.2.4—Object 0x2080: Diagnostic Readings is out of the expected range. This bit remains set until power cycle. It may indicate a system fault.	Yes.
5	DPOT Fault. This bit is set if there is an error reading back the value written to a DPOT. It remains set until power cycle.	Yes.
6	EEPROM Fault. This bit is set if there is an error reading back the value written to EEPROM. It remains set until power cycle.	Yes.
7	DAC Fault. This bit is set if there is an error detected communicating with the DAC. The DAC used (LTC2600) does not support a read-back operation, but it does support daisy-chaining, so the firmware detects a failure by prepending a known value to any commands, and looking for an echo of that known value on the SPI input after sending the command. It remains set until power cycle.	Yes.
6-27	Reserved	
28	Simulated Error. This bit mirrors the “Simulated Error Control” bit in Section 5.2.9—Object 0x7010: Control Codes .	No, but can be used to test user error handling if treated as such.
29	Calibration checksum error. This bit is set if the active calibration did not have a valid checksum when read from EEPROM.	Yes.
30	Saturation. This bit is set whenever a strain gage sample is saturated, and stays high for 32 samples after the last saturated sample, to allow time for the saturated sample’s effect on the filtered data to abate.	Yes.
31	Error: This bit is set whenever any status code bit that indicates an error is set.	Yes

5.2.8 Object 0x6020: Sample Counter

This object contains a single 32-bit unsigned integer at subindex 0 that increments each time an F/T sample (one complete set of gage data) is read.

5.2.9 Object 0x7010: Control Codes

This object is mapped into the RxPDO for real-time control of the F/T system. It contains the following fields:

Table 5.8—Control Codes				
Subindex	Name	Type	Description	
0x01	Control 1	DINT	Bit	Function
			0	1 = Set bias against current load. 0 = Use last set bias.
			1	1 = Select gage output 0 = Select F/T output.
			2	1 = Set test error 0 = clear test error
			3	1 = Clear monitor condition status. 0 = Leave monitor condition status as-is.
			4-7	Filter selection
			8-11	Calibration Selection
			12-31	Reserved
0x02	Control 2	DINT	Bit	Function
			0-15	Monitor condition enable bitmap
			16-19	Tool transform index selection. ¹
			20-30	Reserved
			31	Simulated Error Control
Note: 1. After changing the tool transform index, it is recommended you do not update the control codes for a period of 500 milliseconds to allow the sensor to fully apply the transformation.				

6. Troubleshooting

This section includes answers to some issues that might arise when setting up and using the EtherCAT Sensor system. The question or problem is listed followed by its probable answer or solution. They are categorized for easy reference.

The information in this section should answer many questions that might arise in the field. Customer service is available to users who have problems or questions addressed in the manuals.

ATI Industrial Automation
Attn: F/T Customer Service
 Pinnacle Park
 1031 Goodworth Drive
 Apex, NC 27539 USA

 Phone: +1.919.772.0115
 Fax: +1.919.772.8259
 Email: ft_support@ati-ia.com

NOTICE: Please read the F/T manuals before calling customer service. When calling, have the following information available:

1. Serial number(s)
2. Transducer type (e.g., Nano17, Gamma, Theta)
3. Calibration (e.g., US-15-50, SI-130-10)
4. An accurate and complete description of the question or problem.
5. If possible all information that is displayed on EtherCAT F/T page System Info (manuf.htm). The EtherCAT Sensor has to be connected to a EtherCATBox to access the System Info.

If possible, the F/T system should be accessible when talking with an ATI Industrial Automation customer service representative.

6.1 Errors with Force and Torque Readings

Bad data from the transducer's strain gages can cause errors in force/torque readings. These errors can result in problems with transducer biasing and accuracy. Listed below are the basic conditions of bad data. Use this to troubleshoot your problem.

Question/Problem	Answer/Solution
Noise	Jumps in raw strain gage readings (with transducer unloaded) greater than 80 counts is considered abnormal. Noise can be caused by mechanical vibrations and electrical disturbances, possibly from a poor ground. It can also indicate component failure within the system. Make sure that the DC supply voltage for the EtherCAT sensor has little to no noise superimposed. The EtherCAT sensor provides an optional earth ground connection, refer to Section 3.4—Optional Earth Ground Connection for more information.
Drift	After a load is removed or applied, the raw gage reading does not stabilize, but continues to increase or decrease. This may be observed more easily in resolved data mode using the bias command. Drift is caused by temperature change, mechanical coupling, or internal failure. Mechanical coupling is caused when a physical connection is made between the tool plate and the transducer body (i.e., filings between the tool adapter plate and the transducer body). Some mechanical coupling is common, such as hoses and wires attached to a tool.
Hysteresis	When the transducer is loaded and then unloaded, gage readings do not return quickly and completely to their original readings. Hysteresis is caused by mechanical coupling (explained in Drift section) or internal failure.

7. Specifications

The specification specifically for the EtherCAT sensor interface are covered in this section. Specifications for the different EtherCAT Sensor models such as weight, dimensions, operating and storage temperature are covered in the 9620-05-Transducer Section manual.

7.1 Storage and Operating Conditions

Table 7.1—Temperature		
Component	Storage Temperature, °C	Operating Temperature, °C
EtherCAT Electronics	-40 to +100	-20 to +70

7.2 Electrical Specifications

Table 7.2—Power Supply		
Power Source†	Voltage	Maximum Power Consumption
DC Power Connector	20V min. to 48V max.	3.0W
PoE	36V min. to 57V max.	3.0W

The EtherCAT Sensor power supply input is protected against wrong polarity.

8. Drawings

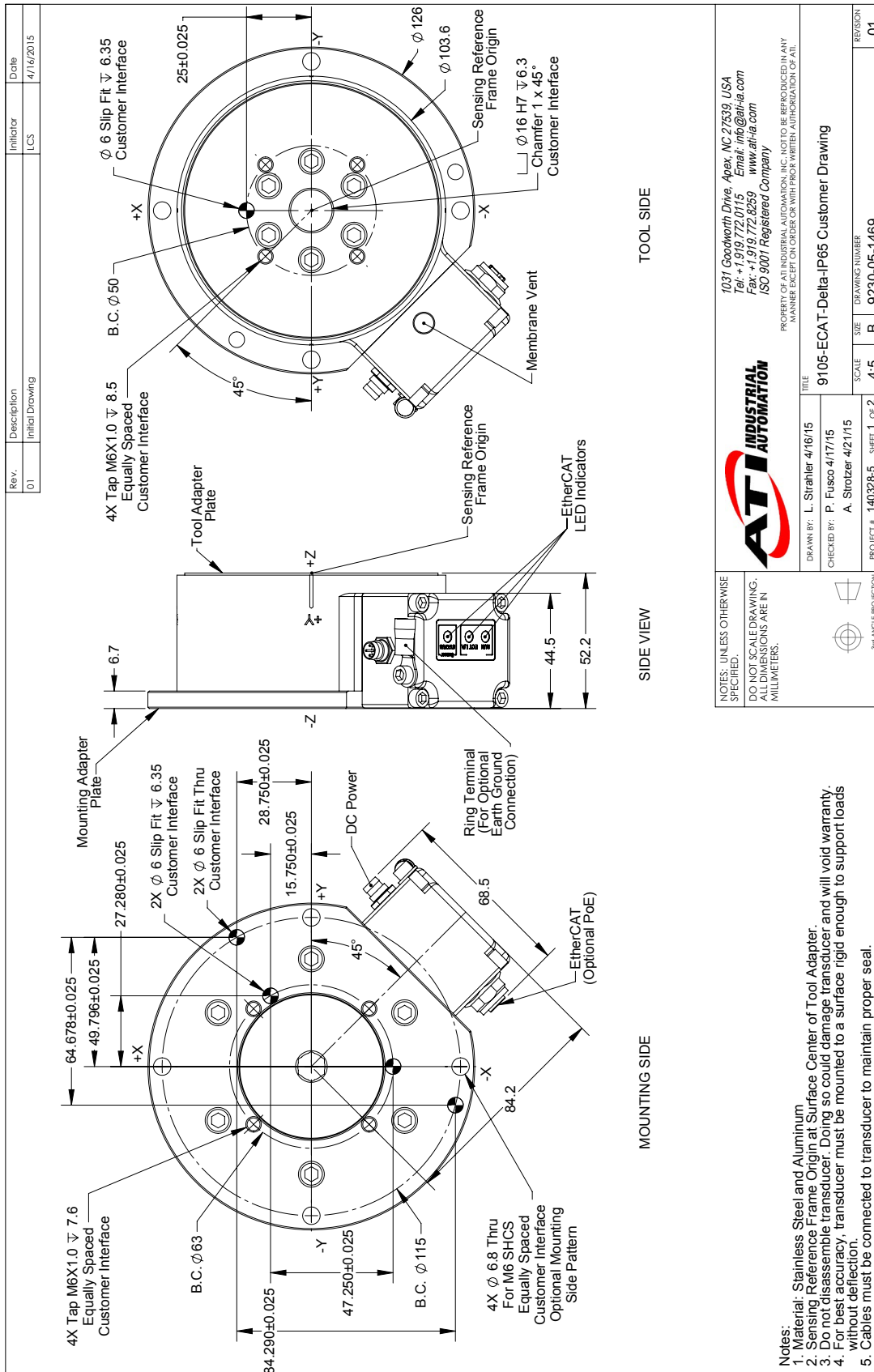

Pin No.	Signal
1	V+
3	GND
4	N/C

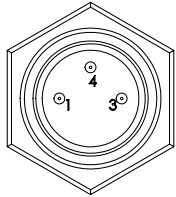

**DC Power Connector
3-Pin Male M8**

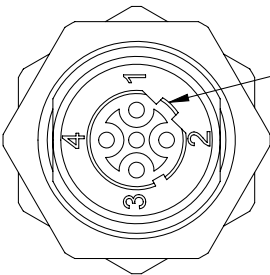

**EtherCAT Connector
4-Pin Female M12 D-Coded**

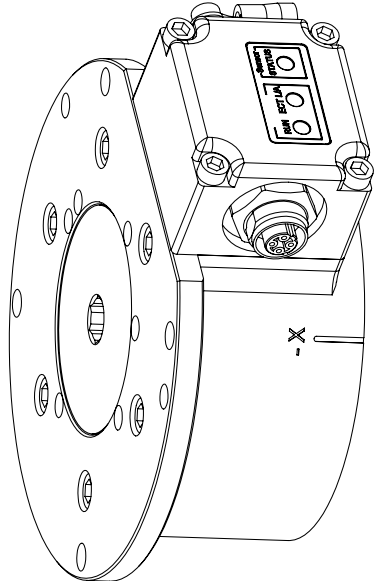



ISOMETRIC VIEW

Pin No.	Signal
1	TX+
2	RX+
3	TX-
4	RX-
Shell	Connector Block Housing

**EtherCAT Connector
4-Pin Female M12 D-Coded**

D-Coded

**NOTES: UNLESS OTHERWISE SPECIFIED:
DO NOT SCALE DRAWING.
ALL DIMENSIONS ARE IN MILLIMETERS.**

3RD ANGLE PROJECTION

ATI INDUSTRIAL AUTOMATION

1031 Goodworth Drive, Apex, NC 27539, USA
 Tel: +1.919.772.0115 Email: info@ati-ia.com
 Fax: +1.919.772.8259 www.ati-ia.com
 ISO 9001 Registered Company

PROPERTY OF ATI INDUSTRIAL AUTOMATION, INC. NOT TO BE REPRODUCED IN ANY MANNER EXCEPT ON ORDER OR WITH PROPER WRITTEN AUTHORIZATION OF ATI.

DRAWN BY: L. Strahler 4/16/15	TITLE: 9105-ECAT-Delta-IP65 Customer Drawing	SCALE: 4:5	REVISION: 01
CHECKED BY: P. Fusco 4/17/15		DRAWING NUMBER: B	
A. Strotzer 4/21/15		SHEET 2 OF 2	
PROJECT # 140328-5			

9. Terms and Conditions of Sale

The following Terms and Conditions are a supplement to and include a portion of ATI's Standard Terms and Conditions, which are on file at ATI and available upon request.

ATI warrants to Purchaser that force torque sensor products purchased hereunder will be free from defects in material and workmanship under normal use for a period of one year from the date of shipment. This warranty does not cover components subject to wear and tear under normal usage or those requiring periodic replacement. ATI will have no liability under this warranty unless: (a) ATI is given written notice of the claimed defect and a description thereof with thirty (30) days after Purchaser discovers the defect and in any event, not later than the last day of the warranty period and (b) the defective item is received by ATI not later than (10) days after the last day of the warranty period. ATI's entire liability and Purchaser's sole remedy under this warranty is limited to repair or replacement, at ATI's election, of the defective part or item or, at ATI's election, refund of the price paid for the item. The foregoing warranty does not apply to any defect or failure resulting from improper installation, operation, maintenance, or repair by anyone other than ATI.

ATI will in no event be liable for incidental, consequential, or special damages of any kind, even if TI has been advised of the possibility of such damages. ATI's aggregate liability will in no event exceed the amount paid by the purchaser for the item which is the subject of claim or dispute. ATI will have no liability of any kind for failure of any equipment or other items not supplied by ATI.

No action against ATI, regardless of form, arising out of or in any way connected with products or services supplied hereunder, may be brought more than one year after the cause of action accrued.

No representation or agreement varying or extending the warranty and limitation of remedy provisions contained herein is authorized by ATI, and may not be relied upon as having been authorized by ATI, unless in writing and signed by an executive officer of ATI.

Unless otherwise agreed in writing by ATI, all designs, drawings, data, inventions, software, and other technology made or developed by ATI in the course of providing products and services hereunder, and all rights therein under any patent, copyright, or other law protecting intellectual property, shall be and remain ATI's property. The sale of products or services hereunder does not convey any expressed or implied license under any patent, copyright, or other intellectual property right owned or controlled by ATI, whether relating to the products sold or any other matter, except for the license expressly granted below.

In the course of supplying products and services hereunder, ATI may provide or disclose to Purchaser confidential and proprietary information of ATI relating to the design, operation, or other aspects of ATI's products. As between ATI and Purchaser, ownership of such information, including without limitation any computer software provided to Purchaser by ATI, shall remain in ATI and such information is licensed to Purchaser only for Purchaser's use in operating the products supplied by ATI hereunder in Purchaser's internal business operations.

Without ATI's prior written permission, Purchaser will not use such information for any other purpose or provide or otherwise make such information available to any third party. Purchaser agrees to take all reasonable precautions to prevent any unauthorized use or disclosure of such information.

Purchaser will not be liable hereunder with respect to disclosure or use of information which: (a) is in the public domain when received from ATI, (b) is thereafter published or otherwise enters the public domain through no fault of Purchaser, (c) is in Purchaser's possession prior to receipt from ATI, (d) is lawfully obtained by Purchaser from a third party entitled to disclose it, or (f) is required to be disclosed by judicial order or other governmental authority, provided that, with respect to such to maintain the confidentiality of such information.