



Robots

KUKA Roboter GmbH

LBR iiwa

LBR iiwa 7 R800, LBR iiwa 14 R820

Specification

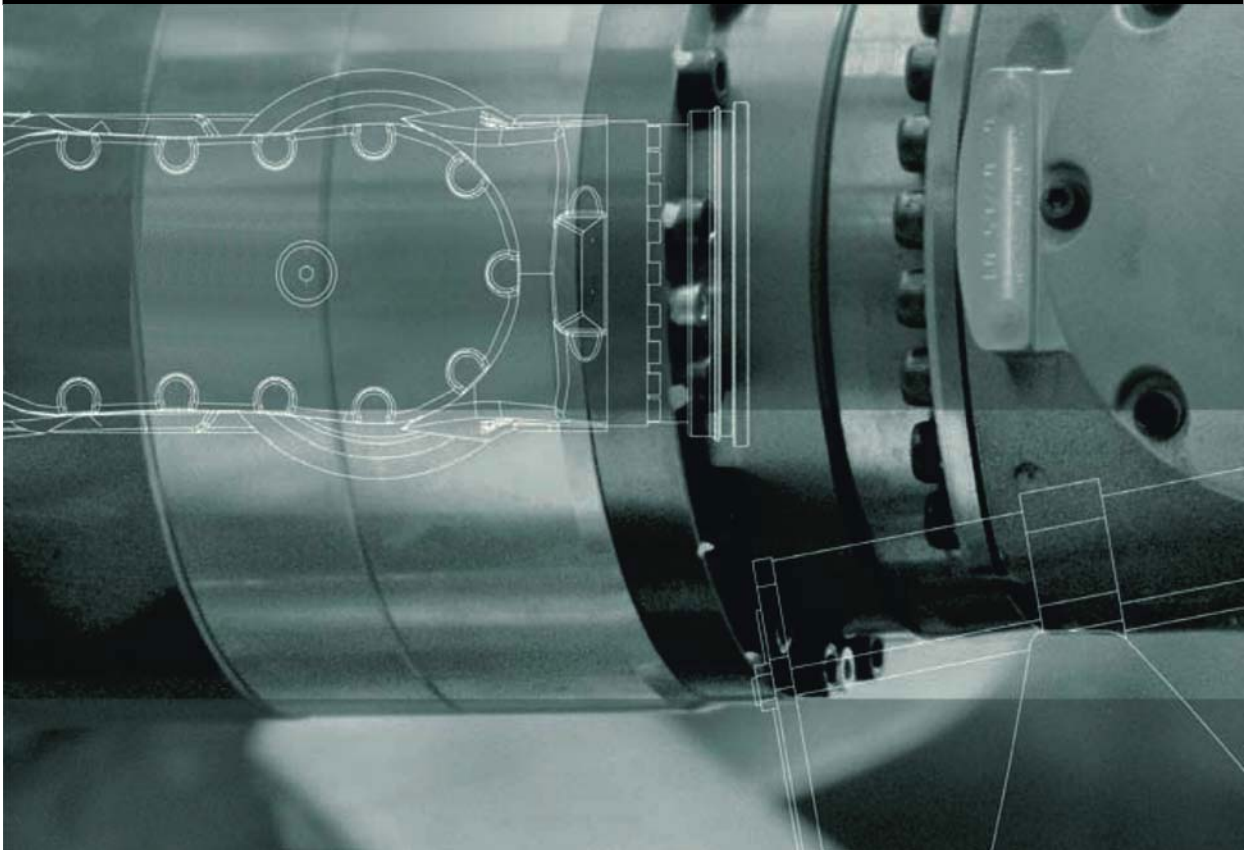

Issued: 23.05.2016

Version: Spez LBR iiwa V7



© Copyright 2016

KUKA Laboratories GmbH
Zugspitzstraße 140
D-86165 Augsburg
Germany

This documentation or excerpts therefrom may not be reproduced or disclosed to third parties without the express permission of the KUKA Laboratories GmbH.

Other functions not described in this documentation may be operable in the controller. The user has no claims to these functions, however, in the case of a replacement or service work.

We have checked the content of this documentation for conformity with the hardware and software described. Nevertheless, discrepancies cannot be precluded, for which reason we are not able to guarantee total conformity. The information in this documentation is checked on a regular basis, however, and necessary corrections will be incorporated in the subsequent edition.

Subject to technical alterations without an effect on the function.

Translation of the original documentation

KIM-PS5-DOC

Publication:	Pub Spez LBR iiwa en
Book structure:	Spez LBR iiwa V4.1
Version:	Spez LBR iiwa V7

Contents

1	Introduction	5
1.1	Industrial robot documentation	5
1.2	Representation of warnings and notes	5
1.3	Terms used	5
2	Purpose	7
2.1	Target group	7
2.2	Intended use	7
3	Product description	9
3.1	Overview of the robot system	9
3.2	Description of the LBR iiwa	9
4	Technical data	11
4.1	Technical data, overview	11
4.2	Technical data, LBR iiwa 7 R800	11
4.2.1	Basic data, LBR iiwa 7 R800	11
4.2.2	Axis data, LBR iiwa 7 R800	12
4.2.3	Payloads, LBR iiwa 7 R800	13
4.2.4	Foundation data, LBR iiwa 7 R800	15
4.3	Technical data, LBR iiwa 14 R820	17
4.3.1	Basic data, LBR iiwa 14 R820	17
4.3.2	Axis data, LBR iiwa 14 R820	17
4.3.3	Payloads, LBR iiwa 14 R820	19
4.3.4	Foundation data, LBR iiwa 14 R820	21
4.4	Plates and labels	22
4.5	Stopping distances and times	23
4.5.1	General information	23
4.5.2	Terms used	24
4.5.3	Stopping distances and stopping times for LBR iiwa 7 R800	26
4.5.3.1	Stopping distances and stopping times for STOP 0, axis 1 to axis 4	26
4.5.3.2	Stopping distances and stopping times for STOP 1, axis 1	27
4.5.3.3	Stopping distances and stopping times for STOP 1, axis 2	29
4.5.3.4	Stopping distances and stopping times for STOP 1, axis 3	31
4.5.3.5	Stopping distances and stopping times for STOP 1, axis 4	33
4.5.4	Stopping distances and stopping times for LBR iiwa 14 R820	34
4.5.4.1	Stopping distances and stopping times for STOP 0, axis 1 to axis 4	35
4.5.4.2	Stopping distances and stopping times for STOP 1, axis 1	36
4.5.4.3	Stopping distances and stopping times for STOP 1, axis 2	38
4.5.4.4	Stopping distances and stopping times for STOP 1, axis 3	40
4.5.4.5	Stopping distances and stopping times for STOP 1, axis 4	42
5	Safety	45
5.1	Legal framework	45
5.1.1	Liability	45
5.1.2	Intended use of the industrial robot	45
5.1.3	EC declaration of conformity and declaration of incorporation	46
5.2	Safety functions	46

5.2.1	Terms used	47
5.2.2	Personnel	48
5.2.3	Workspace, safety zone and danger zone	49
5.2.4	Safety-oriented functions	50
5.2.4.1	EMERGENCY STOP device	51
5.2.4.2	Enabling device	51
5.2.4.3	“Operator safety” signal	52
5.2.4.4	External EMERGENCY STOP device	52
5.2.4.5	External safety stop 1 (path-maintaining)	52
5.2.4.6	External enabling device	53
5.2.4.7	External safe operational stop	53
5.2.5	Triggers for safety-oriented stop reactions	53
5.2.6	Non-safety-oriented functions	54
5.2.6.1	Mode selection	54
5.2.6.2	Software limit switches	55
5.3	Additional protective equipment	56
5.3.1	Jog mode	56
5.3.2	Labeling on the industrial robot	56
5.3.3	External safeguards	56
5.4	Safety measures	57
5.4.1	General safety measures	57
5.4.2	Transportation	58
5.4.3	Start-up and recommissioning	58
5.4.4	Manual mode	60
5.4.5	Automatic mode	61
5.4.6	Maintenance and repair	61
5.4.7	Decommissioning, storage and disposal	62
5.4.8	Safety measures for “single point of control”	62
5.5	Applied norms and directives	63
6	Planning	65
6.1	Mounting variant	65
6.1.1	Machine frame mounting with centering	65
6.2	Connecting cables and interfaces	66
7	Transportation	69
7.1	Transportation	69
7.1.1	Transportation with transport packaging	69
7.1.2	Transportation with transport box (optional)	70
8	KUKA Service	71
8.1	Requesting support	71
8.2	KUKA Customer Support	71
	Index	79

1 Introduction

1.1 Industrial robot documentation

The industrial robot documentation consists of the following parts:

- Documentation for the manipulator
- Documentation for the robot controller
- Operating and programming instructions for the System Software
- Instructions for options and accessories
- Parts catalog on storage medium

Each of these sets of instructions is a separate document.

1.2 Representation of warnings and notes

Safety

These warnings are relevant to safety and **must** be observed.

 DANGER	These warnings mean that it is certain or highly probable that death or severe injuries will occur, if no precautions are taken.
---	---

 WARNING	These warnings mean that death or severe injuries may occur, if no precautions are taken.
--	--

 CAUTION	These warnings mean that minor injuries may occur, if no precautions are taken.
--	--

NOTICE	These warnings mean that damage to property may occur, if no precautions are taken.
---------------	--

	These warnings contain references to safety-relevant information or general safety measures. These warnings do not refer to individual hazards or individual precautionary measures.
---	---

This warning draws attention to procedures which serve to prevent or remedy emergencies or malfunctions:

SAFETY INSTRUCTIONS	Procedures marked with this warning must be followed exactly.
----------------------------	--

Notices

These notices serve to make your work easier or contain references to further information.

	Tip to make your work easier or reference to further information.
---	---

1.3 Terms used

Term	Description
LBR iiwa	Lightweight robot intelligent industrial work assistant

Term	Description
Manipulator	The robot arm and the associated electrical installations
KCP smartPAD	<p>The KCP (KUKA Control Panel) teach pendant has all the operator control and display functions required for operating and programming the industrial robot.</p> <p>The KCP variant for the KUKA Sunrise Cabinet is called KUKA smartPAD. The general term "KCP", however, is generally used in this documentation.</p>

2 Purpose

2.1 Target group

This documentation is aimed at users with the following knowledge and skills:

- Advanced knowledge of mechanical engineering
- Advanced knowledge of electrical and electronic systems
- Knowledge of the robot controller system



For optimal use of our products, we recommend that our customers take part in a course of training at KUKA College. Information about the training program can be found at www.kuka.com or can be obtained directly from our subsidiaries.

2.2 Intended use

Use The industrial robot is intended for handling tools and fixtures, or for processing or transferring components or products. Use is only permitted under the specified environmental conditions.

Misuse Any use or application deviating from the intended use is deemed to be impermissible misuse; examples of such misuse include:

- Transportation of persons and animals
- Use as a climbing aid
- Operation outside the permissible operating parameters
- Use in potentially explosive environments
- Outdoor operation
- Leaning on the robot arm
- Underground operation

NOTICE

Changing the structure of the manipulator, e.g. by drilling holes, etc., can result in damage to the components. This is considered improper use and leads to loss of guarantee and liability entitlements.

3 Product description

3.1 Overview of the robot system

A robot system (>>> Fig. 3-1) comprises all the assemblies of an industrial robot, including the manipulator (mechanical system and electrical installations), controller, connecting cables, end effector (tool) and other equipment.

The industrial robot consists of the following components:

- Manipulator
- KUKA Sunrise Cabinet robot controller
- KUKA smartPAD control panel
- Connecting cables
- Software
- Options, accessories

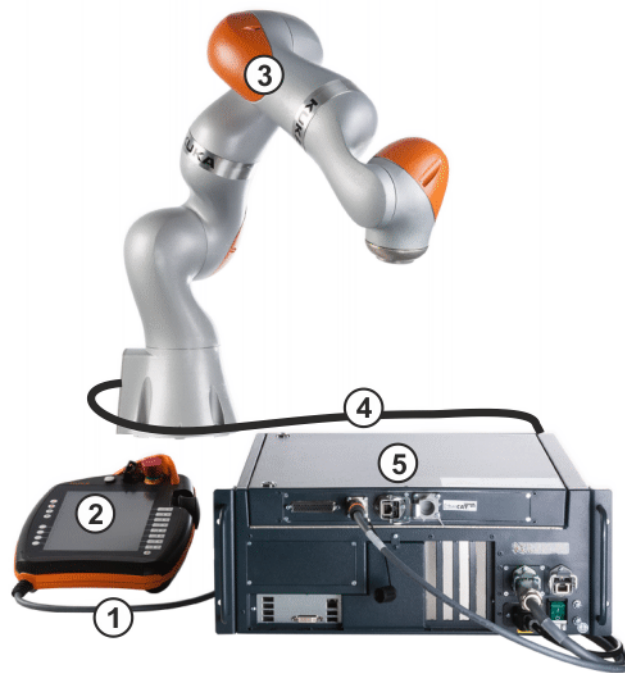

Fig. 3-1: Overview of robot system

- 1 Connecting cable to the smartPAD
- 2 KUKA smartPAD control panel
- 3 Manipulator
- 4 Connecting cable to KUKA Sunrise Cabinet robot controller
- 5 KUKA Sunrise Cabinet robot controller

3.2 Description of the LBR iiwa

Overview

The LBR iiwa is classified as a lightweight robot and is a jointed-arm robot with 7 axes. All drive units and current-carrying cables are installed inside the robot.

Every axis contains multiple sensors that provide signals for robot control (e.g. position control and impedance control) and that are also used as a protective function for the robot. Every axis is monitored by sensors: axis range sensors ensure that the permissible axis range is adhered to, torque sensors ensure that the permissible axis loads are not exceeded, and temperature sensors

monitor the thermal limit values of the electronics. In the case of an unfavorable combination of permanently high demand on robot power and external temperature influences, the LBR is protected by this temperature monitoring which switches it off if the thermal limit values are exceeded. Following a cooling time, the LBR can be restarted with no need for additional measures. Technical Support is available to answer any questions.

The kinematic system of both robot variants is of redundant design due to its 7 axes and consists of the following principal components:

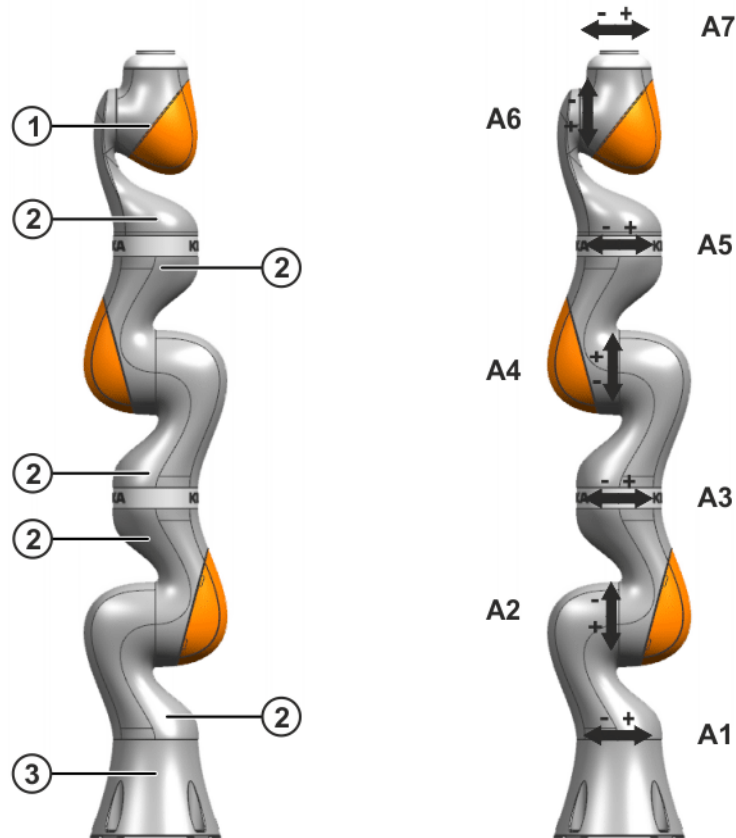

Fig. 3-2: Main assemblies and robot axes

- 1 In-line wrist
- 2 Joint module
- 3 Base frame

In-line wrist

The robot is fitted with a 2-axis in-line wrist. The motors are located in axes A6 and A7.

Joint module

The joint modules consist of an aluminum structure. The drive units are situated inside these modules. In this way, the drive units are linked to one another via the aluminum structures.

Base frame

The base frame is the base of the robot. Interface A1 is located at the rear of the base frame. It constitutes the interface for the connecting cables between the robot, the controller and the energy supply system.

Electrical installations

The electrical installations include all the supply and control cables for the motors of axes A1 (J1) to A7 (J7). All the connections on the motors are plug-and-socket connections. The entire cabling is routed internally in the robot.

The connecting cable is connected to the robot controller. The energy supply system cables are connected to the periphery.

4 Technical data

4.1 Technical data, overview

The technical data for the individual robot types can be found in the following sections:

Robot	Technical data
LBR iiwa 7 R800	<ul style="list-style-type: none"> ■ Basic data (>>> 4.2.1 "Basic data, LBR iiwa 7 R800" Page 11) ■ Axis data (>>> 4.2.2 "Axis data, LBR iiwa 7 R800" Page 12) ■ Payloads (>>> 4.2.3 "Payloads, LBR iiwa 7 R800" Page 13) ■ Mounting base data (>>> 4.2.4 "Foundation data, LBR iiwa 7 R800" Page 15) ■ Plates and labels (>>> 4.4 "Plates and labels" Page 22) ■ Stopping distances and times (>>> 4.5.3 "Stopping distances and stopping times for LBR iiwa 7 R800" Page 26)
LBR iiwa 14 R820	<ul style="list-style-type: none"> ■ Basic data (>>> 4.3.1 "Basic data, LBR iiwa 14 R820" Page 17) ■ Axis data (>>> 4.3.2 "Axis data, LBR iiwa 14 R820" Page 17) ■ Payloads (>>> 4.3.3 "Payloads, LBR iiwa 14 R820" Page 19) ■ Mounting base data (>>> 4.3.4 "Foundation data, LBR iiwa 14 R820" Page 21) ■ Plates and labels (>>> 4.4 "Plates and labels" Page 22) ■ Stopping distances and times (>>> 4.5.4 "Stopping distances and stopping times for LBR iiwa 14 R820" Page 34)

4.2 Technical data, LBR iiwa 7 R800

4.2.1 Basic data, LBR iiwa 7 R800

Basic data

	LBR iiwa 7 R800
Number of axes	7
Number of controlled axes	7
Volume of working envelope	1.7 m ³
Pose repeatability (ISO 9283)	± 0.1 mm
Weight	approx. 23.9 kg
Rated payload	7 kg
Maximum reach	800 mm
Protection rating	IP54
Protection rating, in-line wrist	IP54

	LBR iiwa 7 R800
Sound level	< 75 dB (A)
Mounting position	Floor; Ceiling; Wall
Footprint	-
Permissible angle of inclination	-
Default color	Base frame: white aluminum (RAL 9006); Moving parts: white aluminum (RAL 9006); Cover: KUKA orange 2567
Controller	KUKA Sunrise Cabinet
Transformation name	-

Ambient conditions

Ambient temperature during operation	5 °C to 45 °C (278 K to 318 K)
Ambient temperature during storage/transportation	0 °C to 45 °C (273 K to 318 K)
Air humidity	20 % to 80 %

	In the case of overheating, the robot switches off automatically and is thus protected against thermal destruction.
---	---

4.2.2 Axis data, LBR iiwa 7 R800

Axis data

Range of motion	
A1	±170 °
A2	±120 °
A3	±170 °
A4	±120 °
A5	±170 °
A6	±120 °
A7	±175 °
Speed with rated payload	
A1	98 °/s
A2	98 °/s
A3	100 °/s
A4	130 °/s
A5	140 °/s
A6	180 °/s
A7	180 °/s

Working envelope

The diagram (>>> Fig. 4-1) shows the shape and size of the working envelope for the robot:

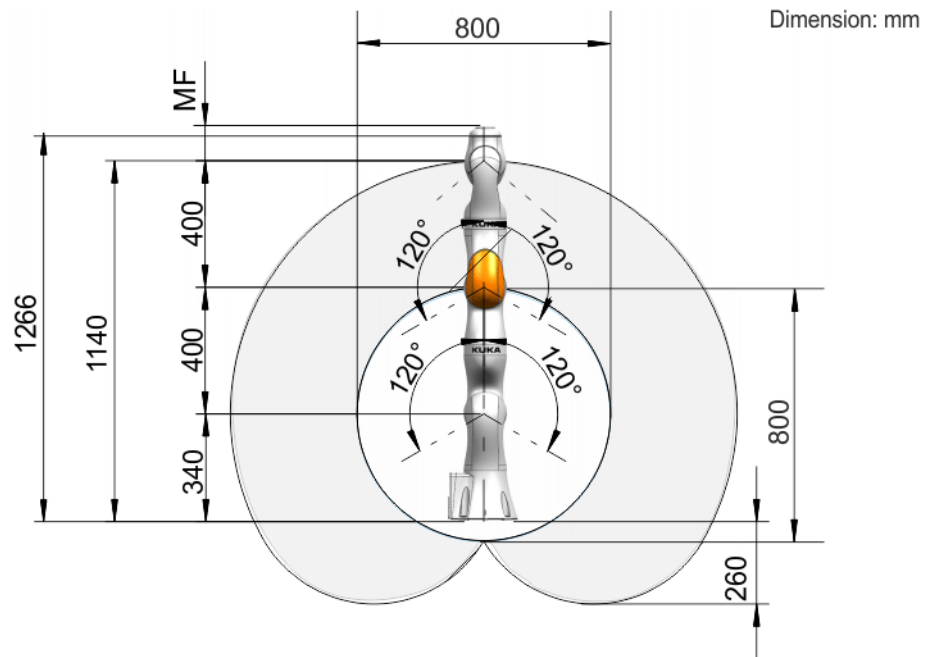

Fig. 4-1: LBR iiwa 7 R800 working envelope, side view

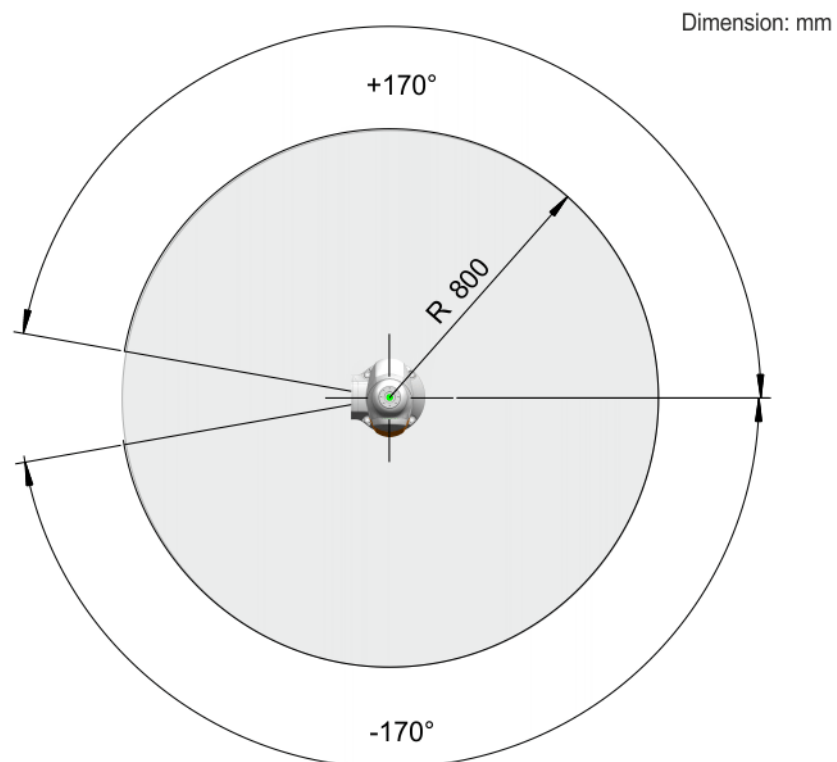

Fig. 4-2: LBR iiwa 7 R800 working envelope, top view

i The height of the LBR iiwa depends on the media flange mounted on it. The dimensions of the media flange can be found in the Media Flange documentation.

4.2.3 Payloads, LBR iiwa 7 R800

Payloads

Rated payload	7 kg
Rated mass moment of inertia	0.3 kgm ²

Rated total load	7 kg
Rated supplementary load, base frame	0 kg
Maximum supplementary load, base frame	-
Rated supplementary load, rotating column	0 kg
Maximum supplementary load, rotating column	-
Rated supplementary load, link arm	0 kg
Maximum supplementary load, link arm	-
Rated supplementary load, arm	0 kg
Maximum supplementary load, arm	-
Nominal distance to load center of gravity	
Lxy	35 mm
Lz	60 mm

Load center of gravity

For all payloads, the load center of gravity refers to the distance from the face of the mounting flange on axis A7.

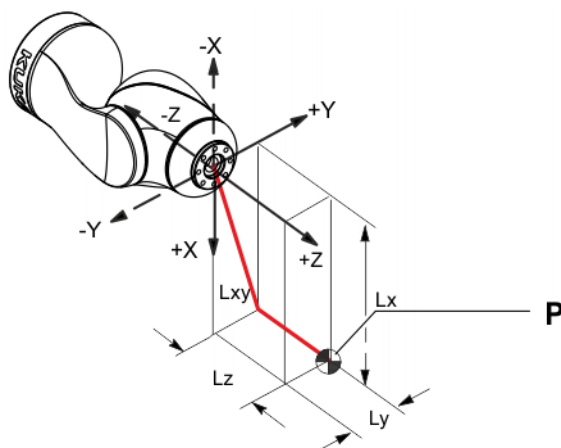

Fig. 4-3: Load center of gravity

Permissible mass inertia at the design point (L_x , L_y , L_z) is 0.3 kgm^2 .

Payload diagram

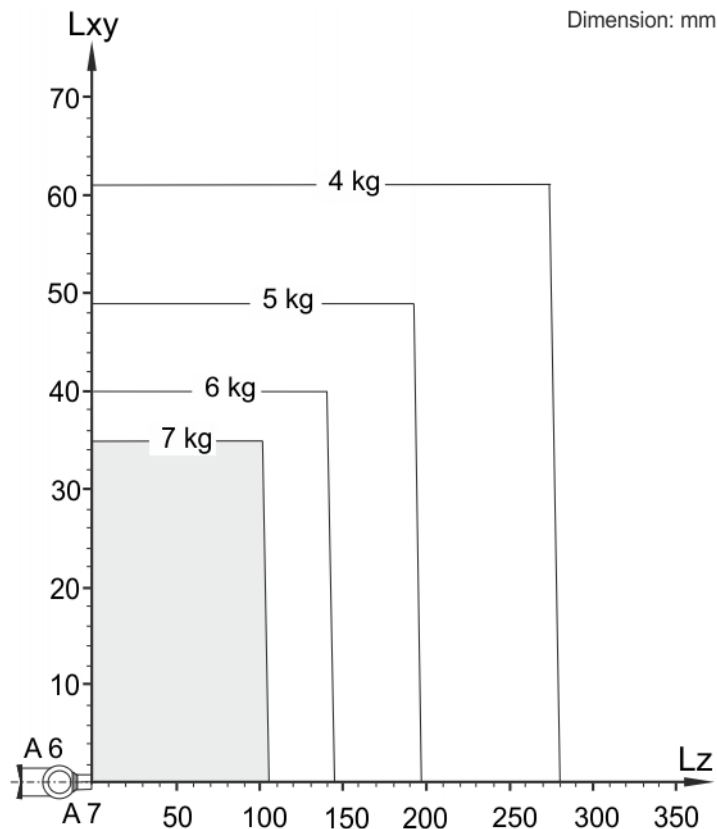

Fig. 4-4: LBR iiwa 7 R800 payload diagram



The payloads depend on the type of media flange used. Further information about the payloads dependent on the media flange can be found in the **Media Flange** documentation.

NOTICE

This loading curve corresponds to the maximum load capacity. Both values (payload and mass moment of inertia) must be checked in all cases. Exceeding this capacity will reduce the service life of the robot and overload the motors and the gears; in any such case KUKA Customer Support must be consulted beforehand. The values determined here are necessary for planning the robot application. For commissioning the robot, additional input data are required in accordance with the operating and programming instructions of the control software.

Supplementary load

The robot cannot carry a supplementary load.

4.2.4 Foundation data, LBR iiwa 7 R800
Mounting base loads

The specified forces and moments already include the payload and the inertia force (weight) of the robot.

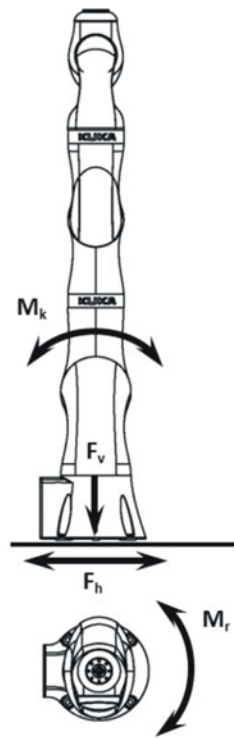

Fig. 4-5: Loads acting on the foundation, floor mounting

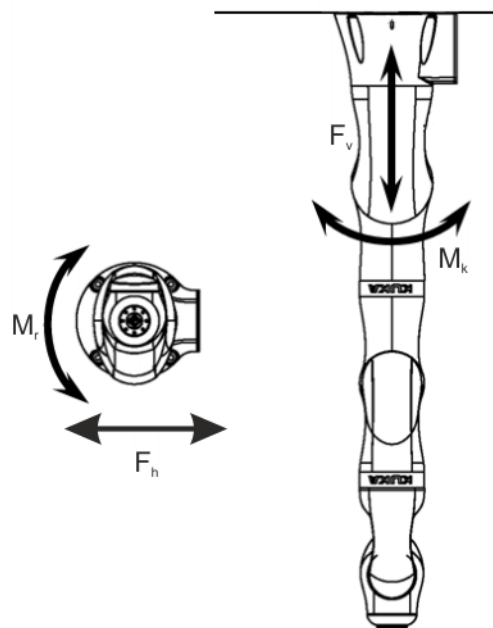

Fig. 4-6: Loads acting on the foundation, ceiling mounting

Vertical force F(v)	
F(v normal)	-
F(v max)	524 N
Horizontal force F(h)	
F(h normal)	-
F(h max)	240 N
Tilting moment M(k)	
M(k normal)	-
M(k max)	310 Nm

Torque about axis 1 M(r)	
M(r normal)	-
M(r max)	156 Nm

NOTICE The foundation loads specified in the table are the maximum loads that may occur. They must be referred to when dimensioning the foundations and must be adhered to for safety reasons. Failure to do so may result in material damage.

4.3 Technical data, LBR iiwa 14 R820

4.3.1 Basic data, LBR iiwa 14 R820

Basic data

	LBR iiwa 14 R820
Number of axes	7
Number of controlled axes	7
Volume of working envelope	1.8 m ³
Pose repeatability (ISO 9283)	± 0.15 mm
Weight	approx. 29.9 kg
Rated payload	14 kg
Maximum reach	820 mm
Protection rating	IP54
Protection rating, in-line wrist	IP54
Sound level	< 75 dB (A)
Mounting position	Floor; Ceiling; Wall
Footprint	-
Permissible angle of inclination	-
Default color	Base frame: white aluminum (RAL 9006); Moving parts: white aluminum (RAL 9006); Cover: KUKA orange 2567
Controller	KUKA Sunrise Cabinet
Transformation name	-

Ambient conditions

Ambient temperature during operation	5 °C to 45 °C (278 K to 318 K)
Ambient temperature during storage/transportation	0 °C to 45 °C (273 K to 318 K)
Air humidity	20 % to 80 %



In the case of overheating, the robot switches off automatically and is thus protected against thermal destruction.

4.3.2 Axis data, LBR iiwa 14 R820

Axis data

Range of motion	
A1	±170 °

A2	±120 °
A3	±170 °
A4	±120 °
A5	±170 °
A6	±120 °
A7	±175 °
Speed with rated payload	
A1	85 °/s
A2	85 °/s
A3	100 °/s
A4	75 °/s
A5	130 °/s
A6	135 °/s
A7	135 °/s

Working envelope

The diagram (>>> Fig. 4-7) shows the shape and size of the working envelope for the robot:

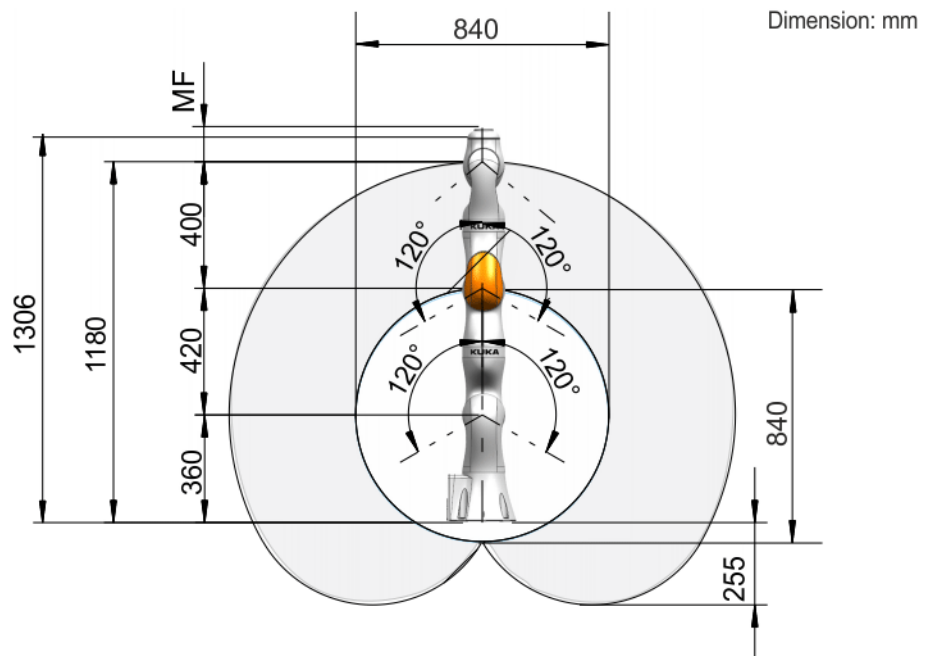

Fig. 4-7: LBR iiwa 14 R820 working envelope, side view

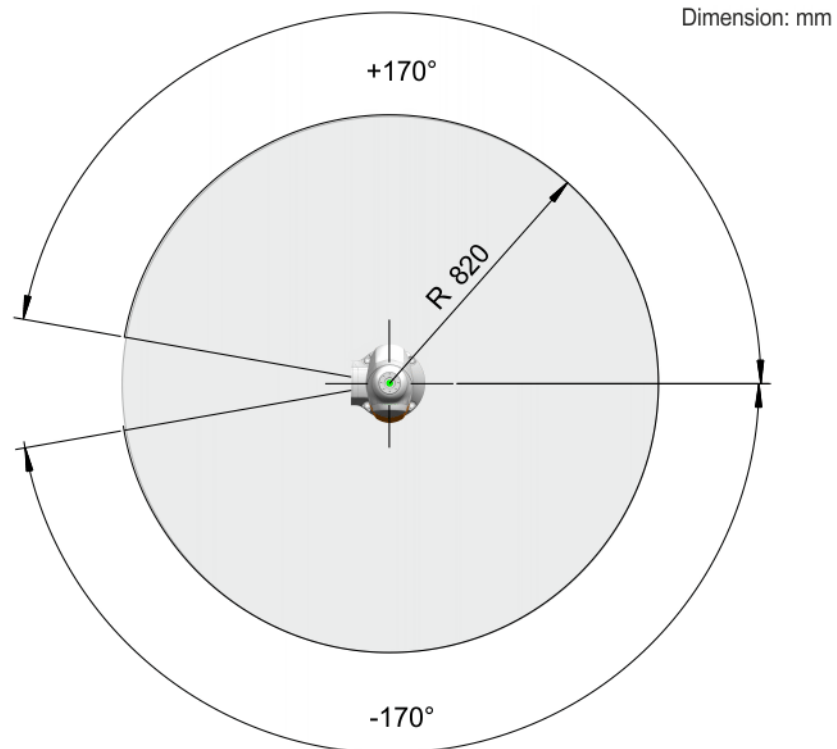

Fig. 4-8: LBR iiwa 14 R820 working envelope, top view



The height of the LBR iiwa depends on the media flange mounted on it. The dimensions of the media flange can be found in the Media Flange documentation.

4.3.3 Payloads, LBR iiwa 14 R820

Payloads

Rated payload	14 kg
Rated mass moment of inertia	0.3 kgm ²
Rated total load	14 kg
Rated supplementary load, base frame	0 kg
Maximum supplementary load, base frame	-
Rated supplementary load, rotating column	0 kg
Maximum supplementary load, rotating column	-
Rated supplementary load, link arm	0 kg
Maximum supplementary load, link arm	-
Rated supplementary load, arm	0 kg
Maximum supplementary load, arm	-
Nominal distance to load center of gravity	
Lxy	40 mm
Lz	44 mm

Load center of gravity

For all payloads, the load center of gravity refers to the distance from the face of the mounting flange on axis A7.

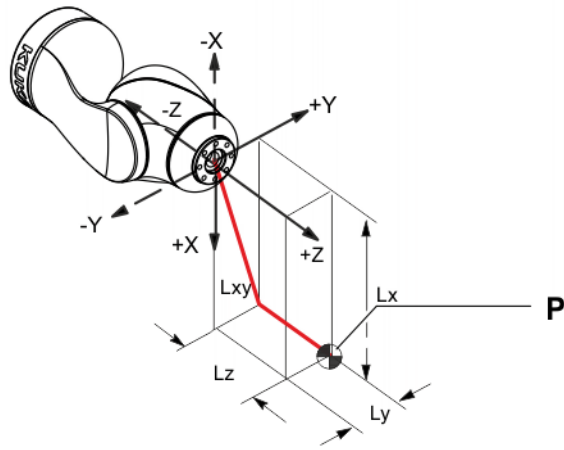

Fig. 4-9: Load center of gravity

Permissible mass inertia at the design point (L_x, L_y, L_z) is 0.3 kgm².

Payload diagram

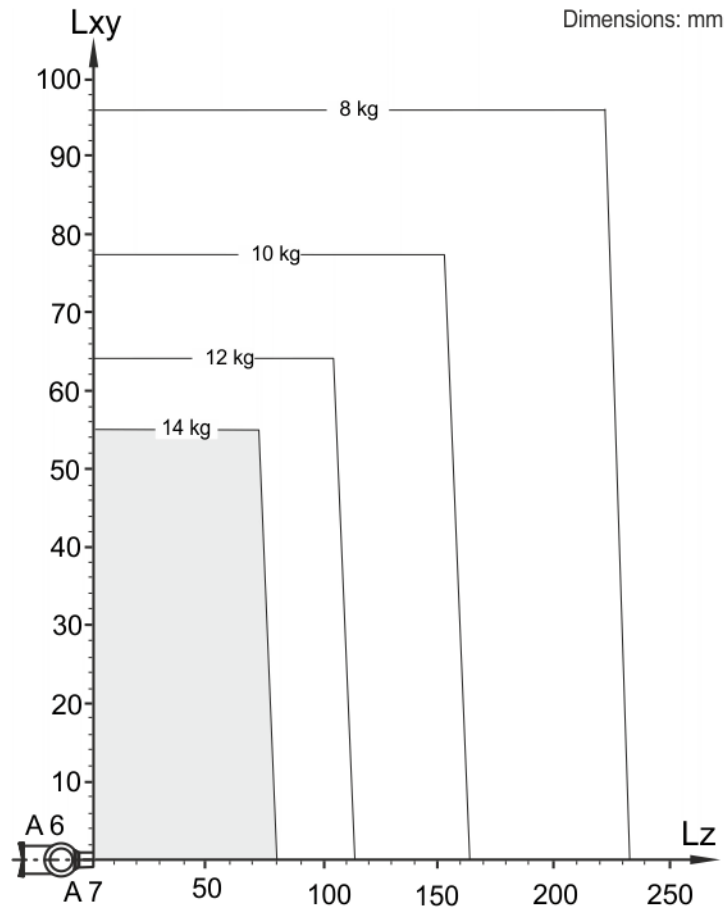

Fig. 4-10: LBR iiwa 14 R820 payload diagram

i The payloads depend on the type of media flange used. Further information about the payloads dependent on the media flange can be found in the **Media Flange** documentation.

NOTICE

This loading curve corresponds to the maximum load capacity. Both values (payload and mass moment of inertia) must be checked in all cases. Exceeding this capacity will reduce the service life of the robot and overload the motors and the gears; in any such case KUKA Customer Support must be consulted beforehand.

The values determined here are necessary for planning the robot application. For commissioning the robot, additional input data are required in accordance with the operating and programming instructions of the control software.

Supplementary load

The robot cannot carry a supplementary load.

4.3.4 Foundation data, LBR iiwa 14 R820**Mounting base loads**

The specified forces and moments already include the payload and the inertia force (weight) of the robot.

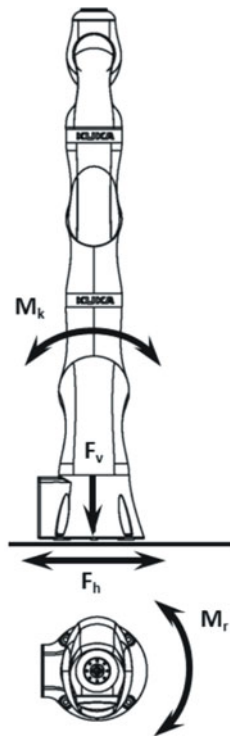

Fig. 4-11: Loads acting on the foundation, floor mounting

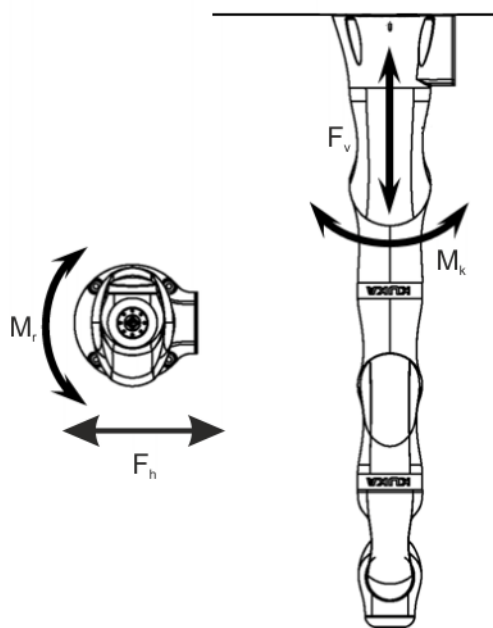

Fig. 4-12: Loads acting on the foundation, ceiling mounting

Vertical force $F(v)$	
$F(v)$ normal	-
$F(v)$ max	541.2 N
Horizontal force $F(h)$	
$F(h)$ normal	-
$F(h)$ max	228.4 N
Tilting moment $M(k)$	
$M(k)$ normal	-
$M(k)$ max	281.6 Nm
Torque about axis 1 $M(r)$	
$M(r)$ normal	-
$M(r)$ max	172.6 Nm

NOTICE The foundation loads specified in the table are the maximum loads that may occur. They must be referred to when dimensioning the foundations and must be adhered to for safety reasons. Failure to do so may result in material damage.

4.4 Plates and labels

Identification plate

The following plates and labels are attached to the robot. They must not be removed or rendered illegible. Illegible plates and labels must be replaced.

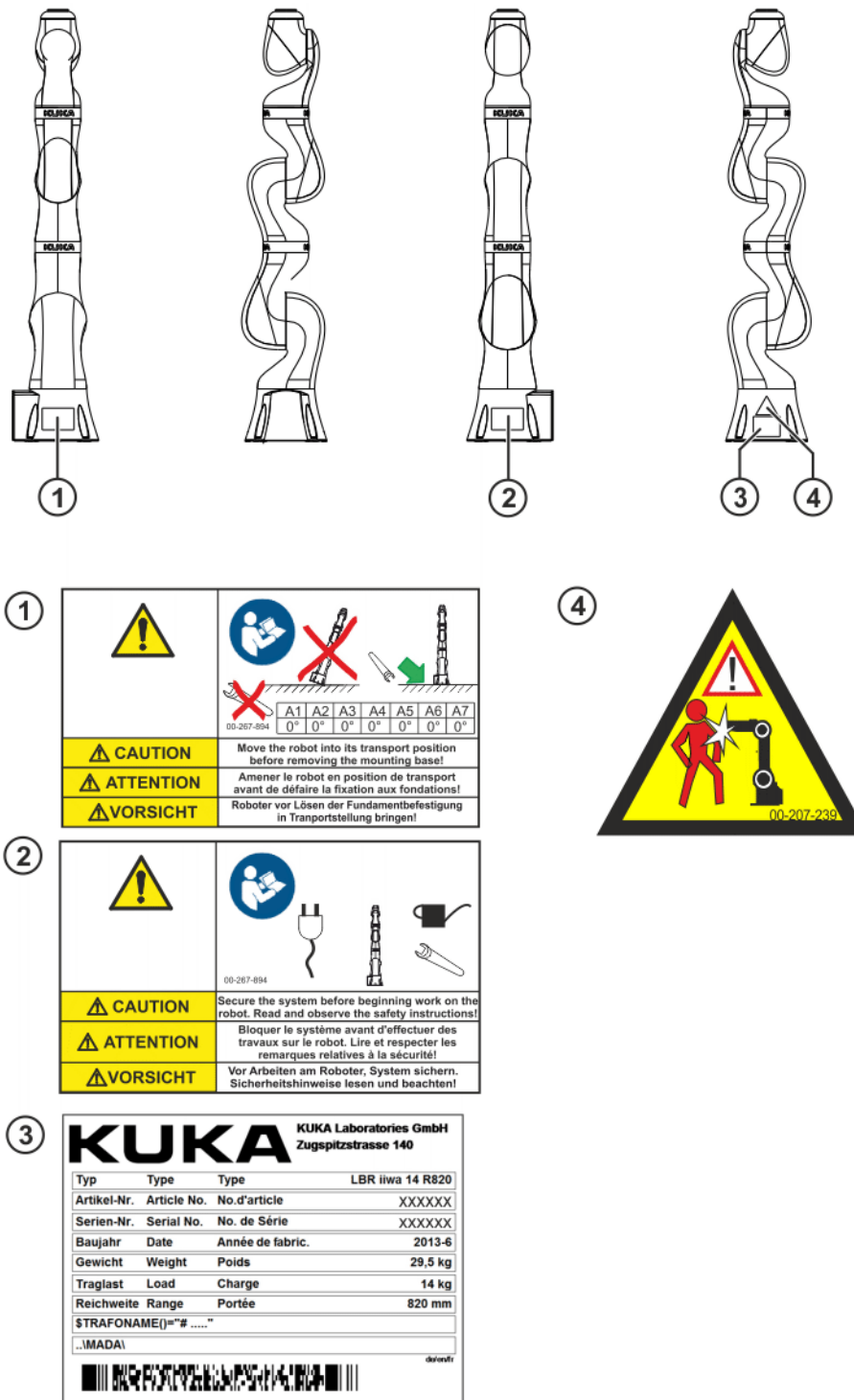

Fig. 4-13: Plates and labels

4.5 Stopping distances and times

4.5.1 General information

Information concerning the position control data:

- The stopping distance is the axis angle traveled by the robot from the moment the stop signal is triggered until the robot comes to a complete standstill.

- The stopping time is the time that elapses from the moment the stop signal is triggered until the robot comes to a complete standstill.
- The data are given for axes A1, A2, A3 and A4. These axes are the axes with the greatest deflection.
- The data apply to single-axis motions. Superposed axis motions can result in longer stopping distances.
- As reference, PTP motions with position control have been used without further parameterization (e.g. robot.move(ptp(Zielpose))).
- Stopping distances and stopping times in accordance with DIN EN ISO 10218-1, Annex B.
- Stop categories:
 - Stop category 0 » STOP 0
 - Stop category 1 » STOP 1 (path-maintaining) according to IEC 60204-1
- The values specified are guide values determined by means of tests and simulation. They are average values which conform to the requirements of DIN EN ISO 10218-1. The actual stopping distances and stopping times may differ due to internal and external influences on the braking torque. It is therefore advisable to determine the exact stopping distances and stopping times under the real conditions of the actual robot application.
- Measuring technique

The stopping distances were measured using the robot-internal measuring technique with rated payloads.
- The wear on the brakes varies depending on the operating mode, robot application and the number of STOP 0 stops triggered. It is therefore advisable to check the stopping distance at least once a year.

The stopping distances and stopping times can be determined, for example, by using safety monitoring to trigger axis-specific or Cartesian workspace monitoring of the safety stop that is to be checked and evaluating the corresponding measured data from the trace (by means of DataRecorder).

4.5.2 Terms used

Term	Description
m	Mass of the rated load and the supplementary load on the arm.
Phi	Angle of rotation (°) about the corresponding axis. This value can be entered in the controller via the KCP and is displayed on the KCP.
POV	Program override (%) = velocity of the robot motion. This value can be entered in the controller via the KCP and is displayed on the KCP.
Extension	Distance (l in %) between axis 1 and the intersection of axes 6 and 7.
KCP	The KCP teach pendant has all the operator control and display functions required for operating and programming the robot system.

Extension

The following figures illustrate the 0%, 33%, 66% and 100% extensions of axes A1-A4:

Extension 0%

The robot is in 0% extension when the axes are in the following positions:

Axis	A1 (J1)	A2 (J2)	A3 (J4)	A4 (J5)	A5 (J6)	A6 (J7)	A7 (J8)
1	0°	0°	0°	0°	0°	0°	0°
2	0°	0°	90°	0°	0°	0°	0°
3	0°	90°	0°	90°	0°	0°	0°
4	0°	90°	0°	90°	90°	0°	0°

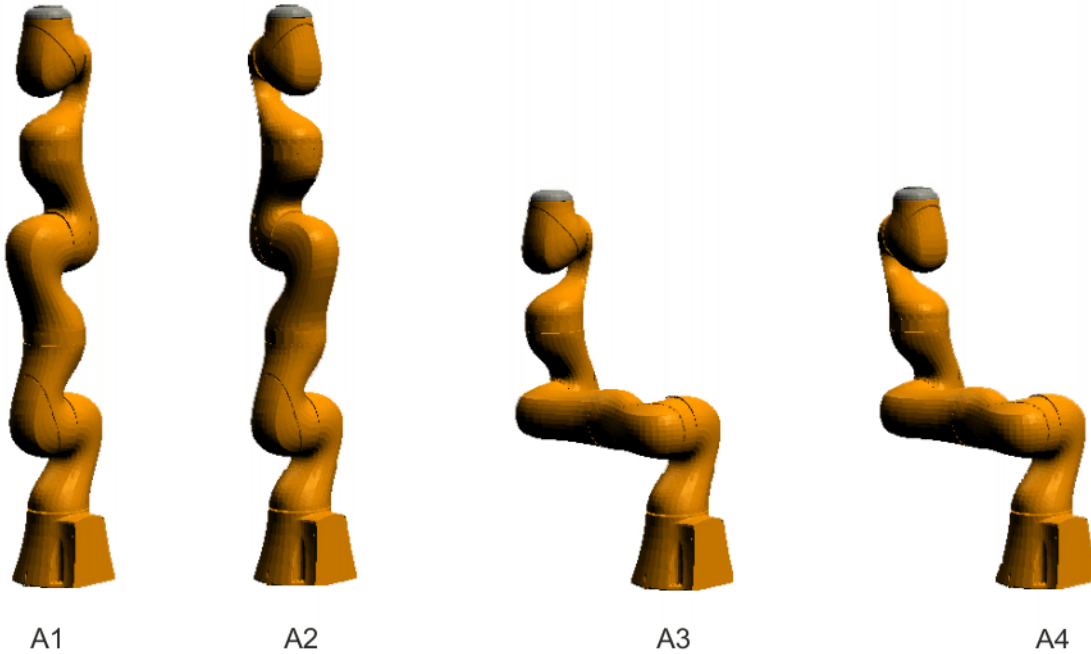

Fig. 4-14: Extension 0%, axis 1 - axis 4

Extension 33%

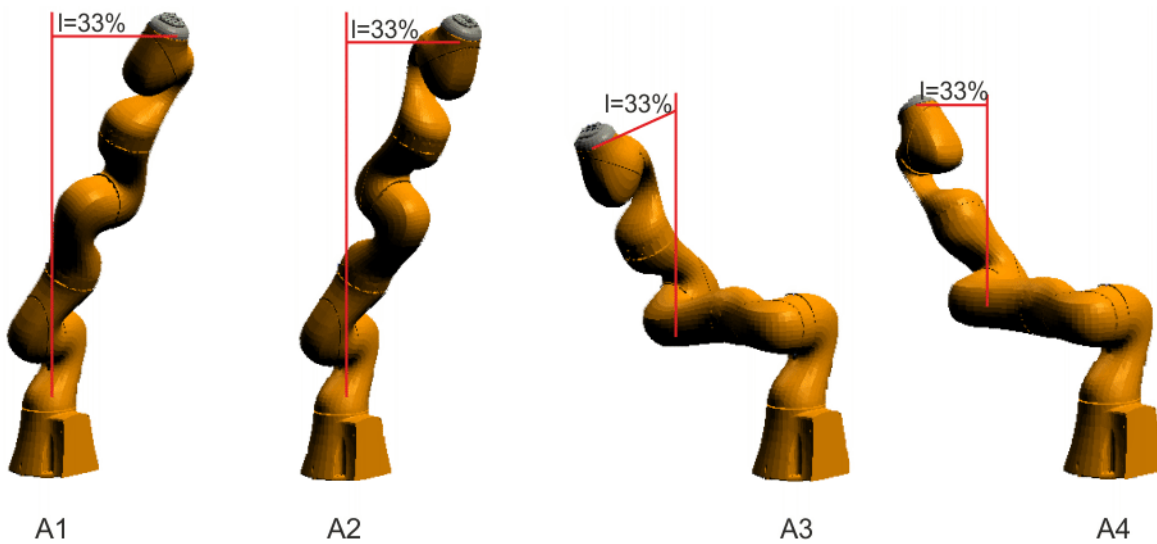

Fig. 4-15: Extension 33%, axis 1 - axis 4

Extension 66%

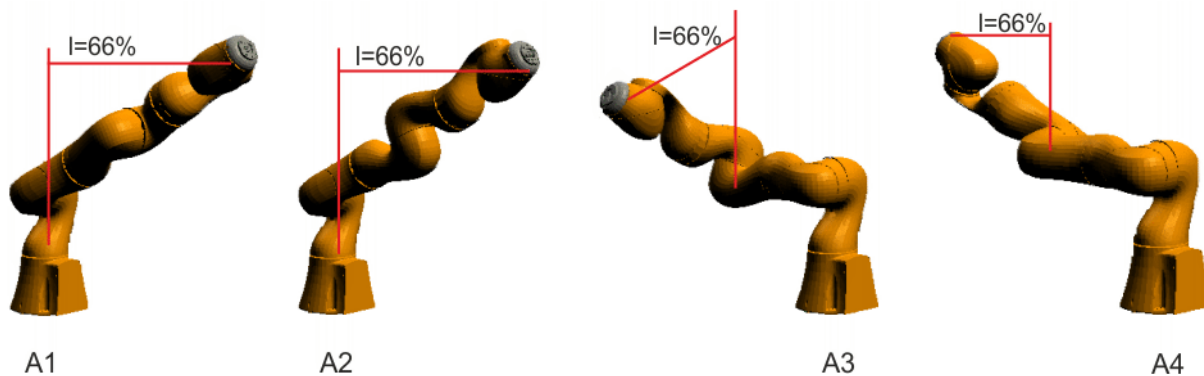

Fig. 4-16: 66% extension, axis 1 - axis 4

Extension 100%

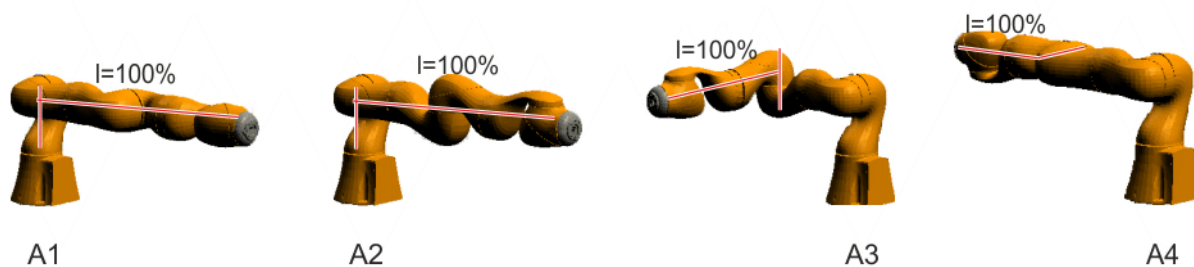

Fig. 4-17: Extension 100%, axis 1 - axis 4

4.5.3 Stopping distances and stopping times for LBR iiwa 7 R800

The stopping distances and stopping times indicated apply to the following media flange:

- Basic flange

i The stopping distances and times of other media flanges are specified in the media flange assembly and operating instructions.

4.5.3.1 Stopping distances and stopping times for STOP 0, axis 1 to axis 4

The table shows the stopping distances and stopping times after a STOP 0 (category 0 stop) is triggered. The values refer to the following configuration:

- Extension $l = 100\%$
- Program override POV = 100%
- Mass $m =$ maximum load (rated load + supplementary load on arm)

	Stopping distance (°)	Stopping time (s)
Axis 1	5.193	0.182
Axis 2	5.092	0.212
Axis 3	8.091	0.166
Axis 4	7.538	0.114

4.5.3.2 Stopping distances and stopping times for STOP 1, axis 1

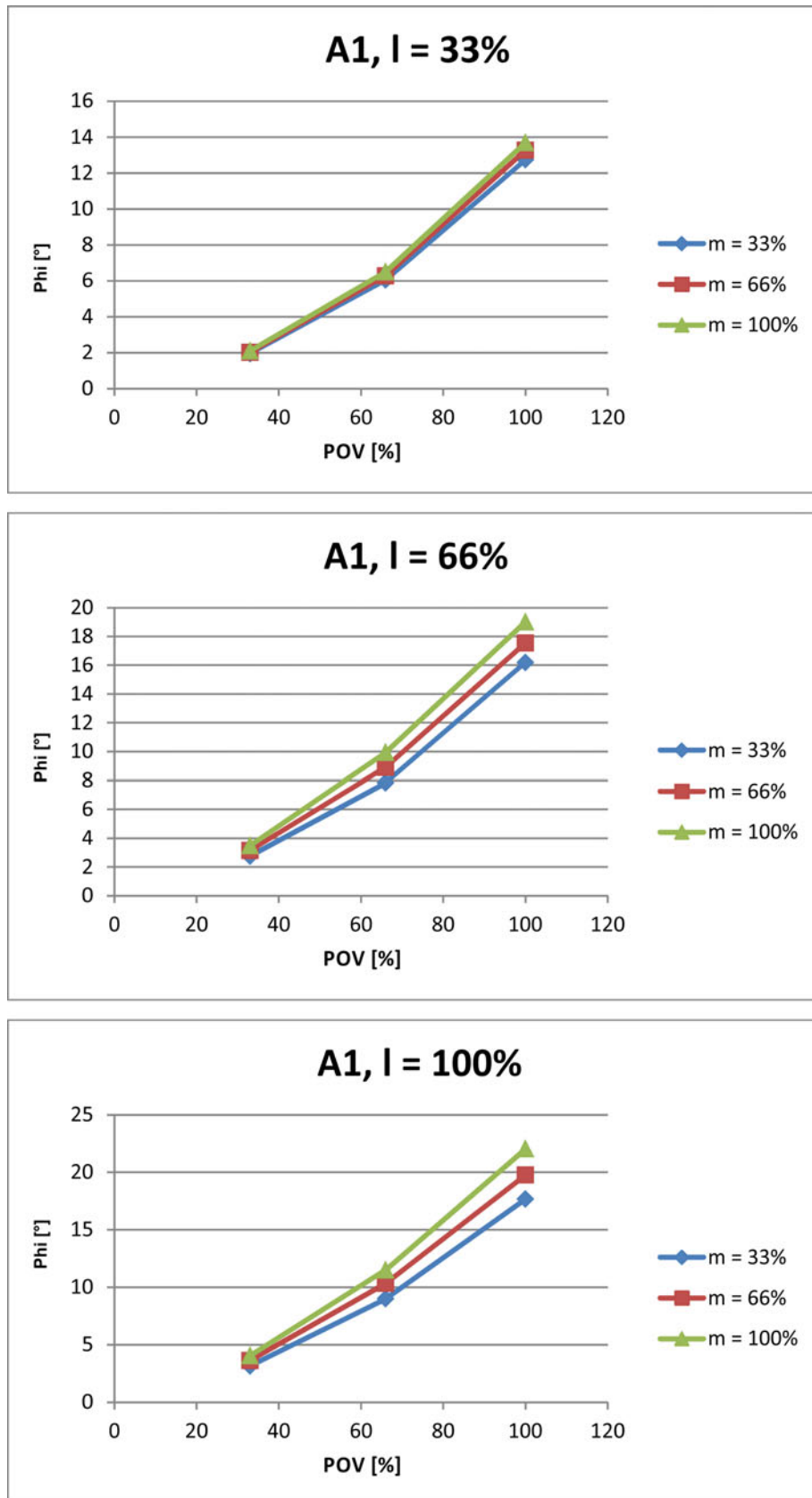

Fig. 4-18: Stopping distances for STOP 1, axis 1

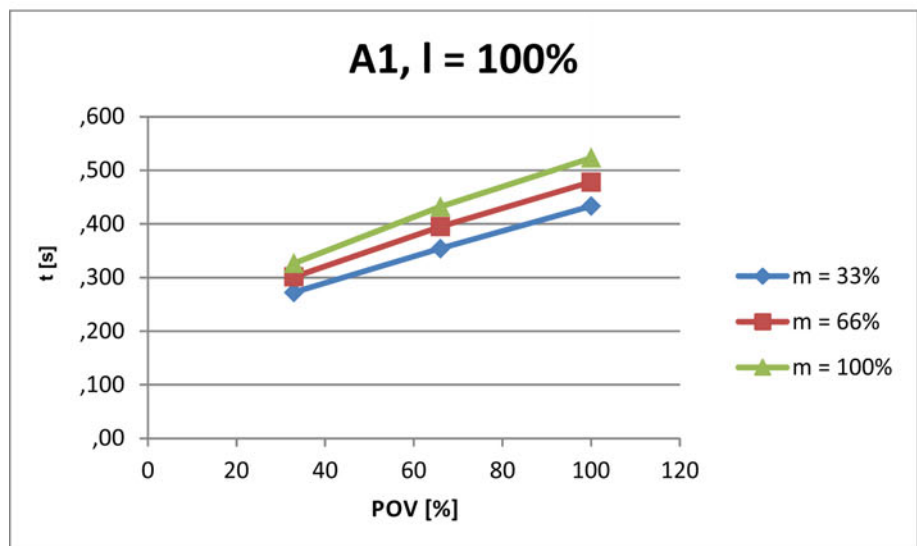
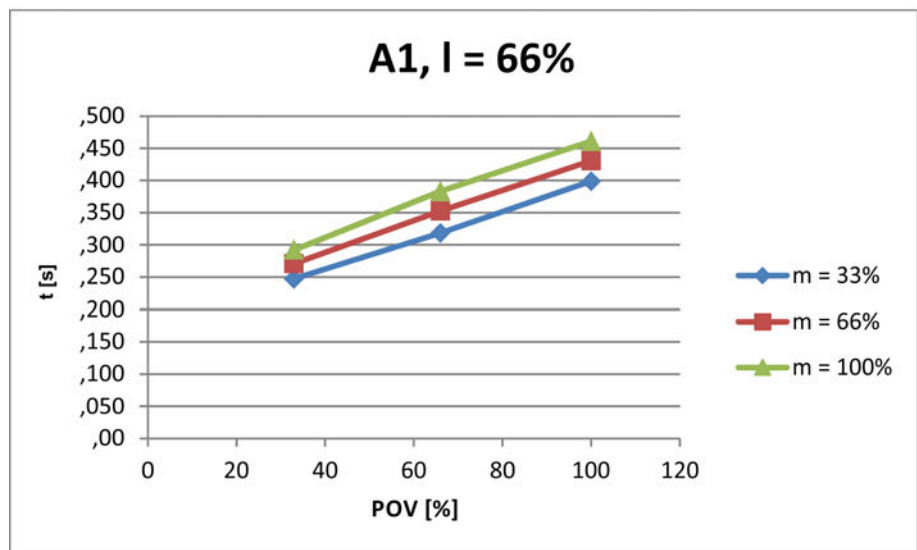
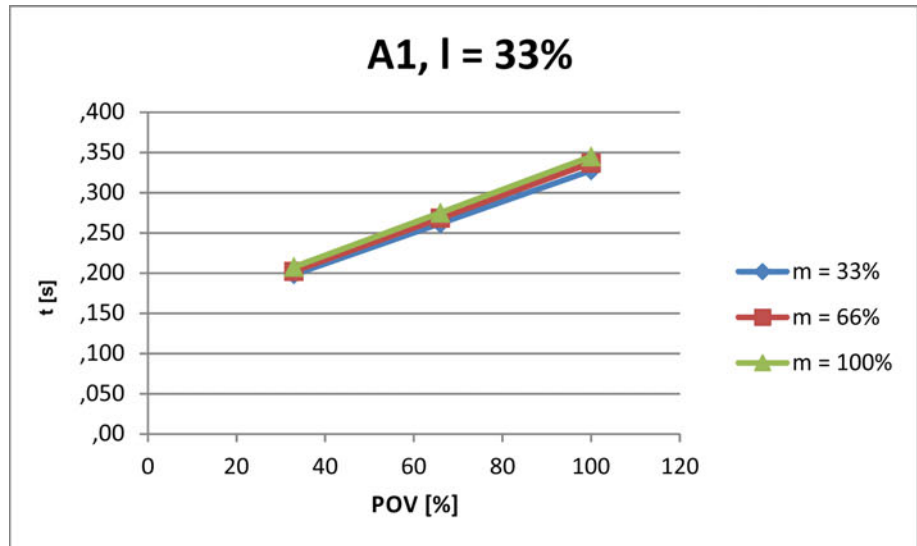

Fig. 4-19: Stopping times for STOP 1, axis 1

4.5.3.3 Stopping distances and stopping times for STOP 1, axis 2

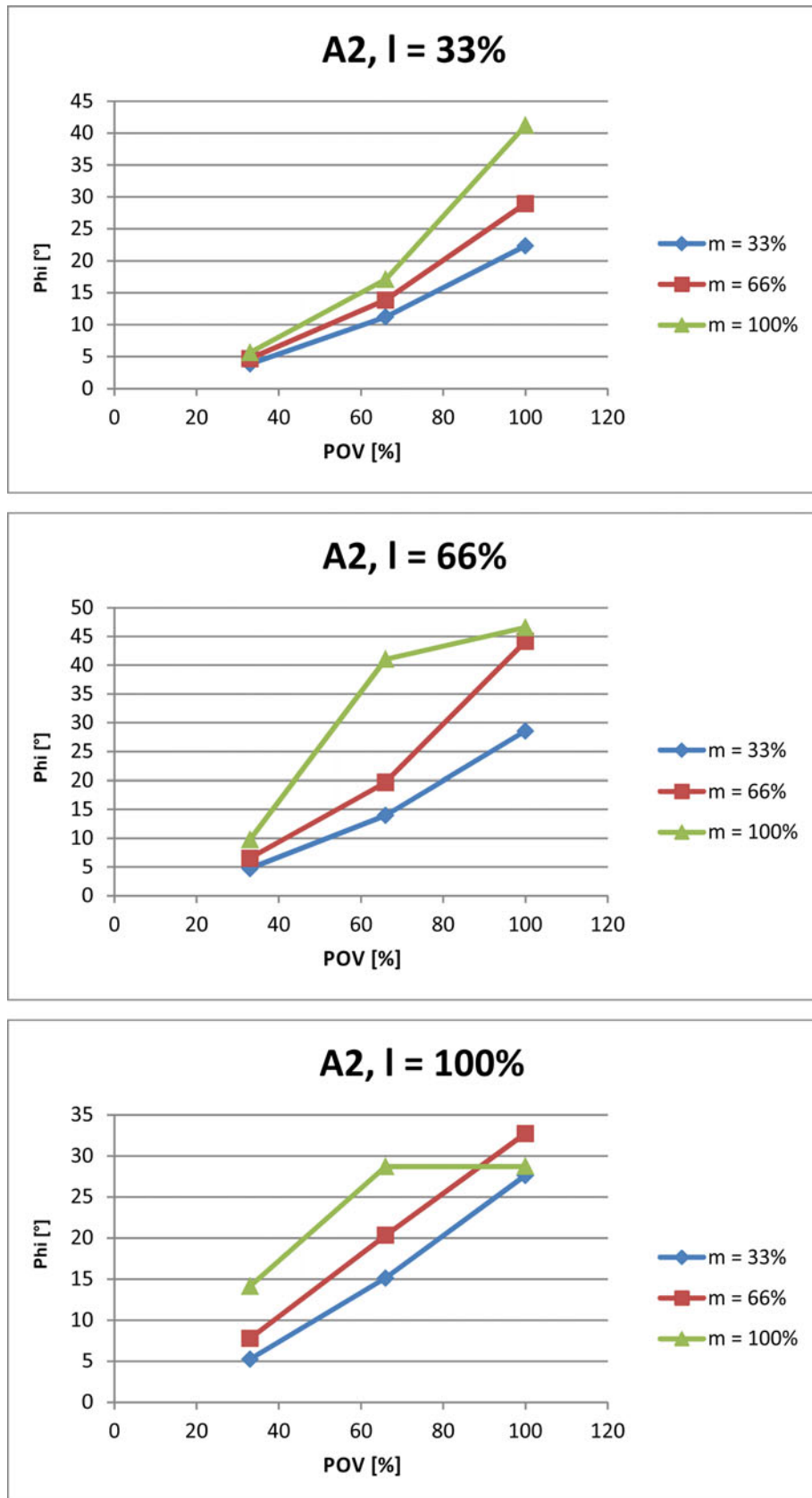

Fig. 4-20: Stopping distances for STOP 1, axis 2

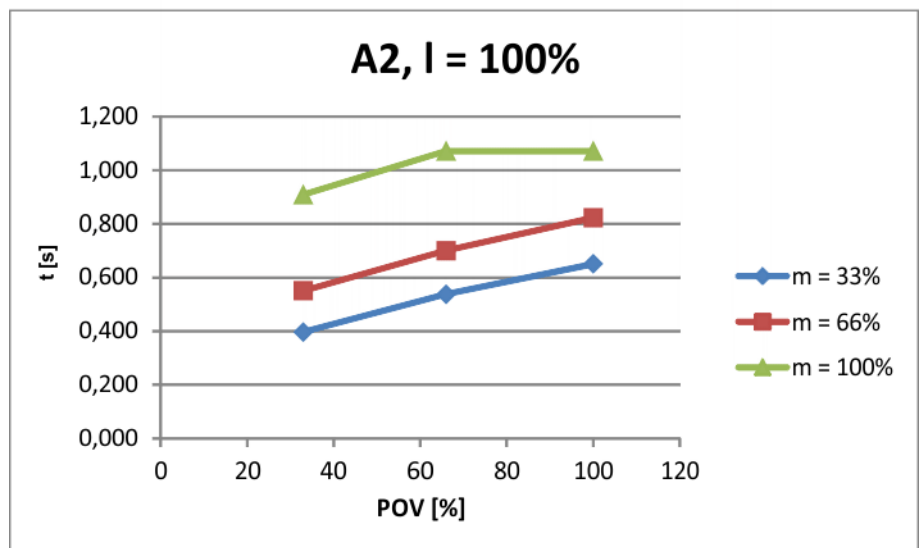
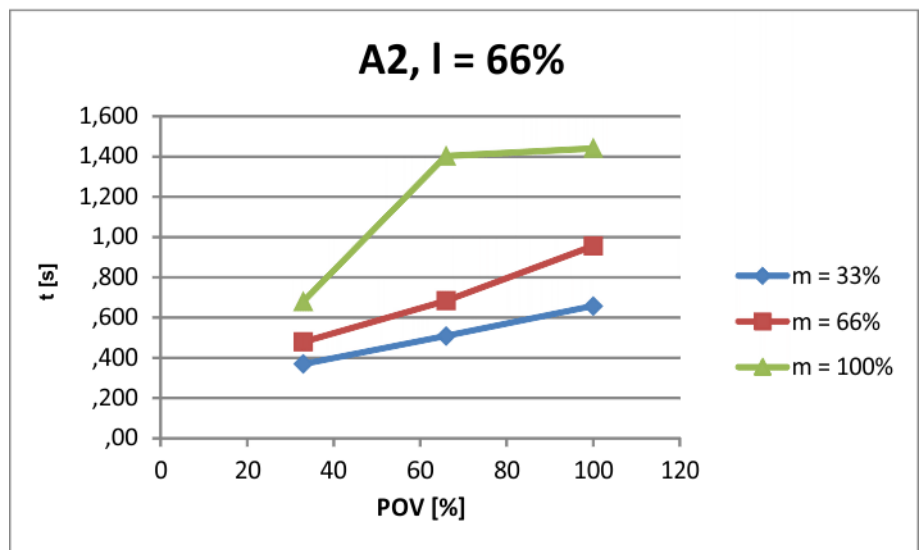
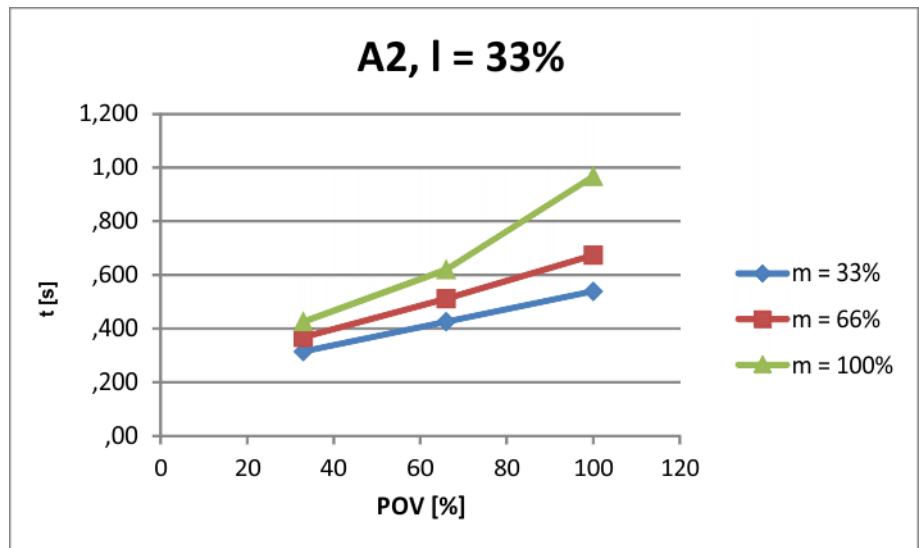

Fig. 4-21: Stopping times for STOP 1, axis 2

4.5.3.4 Stopping distances and stopping times for STOP 1, axis 3

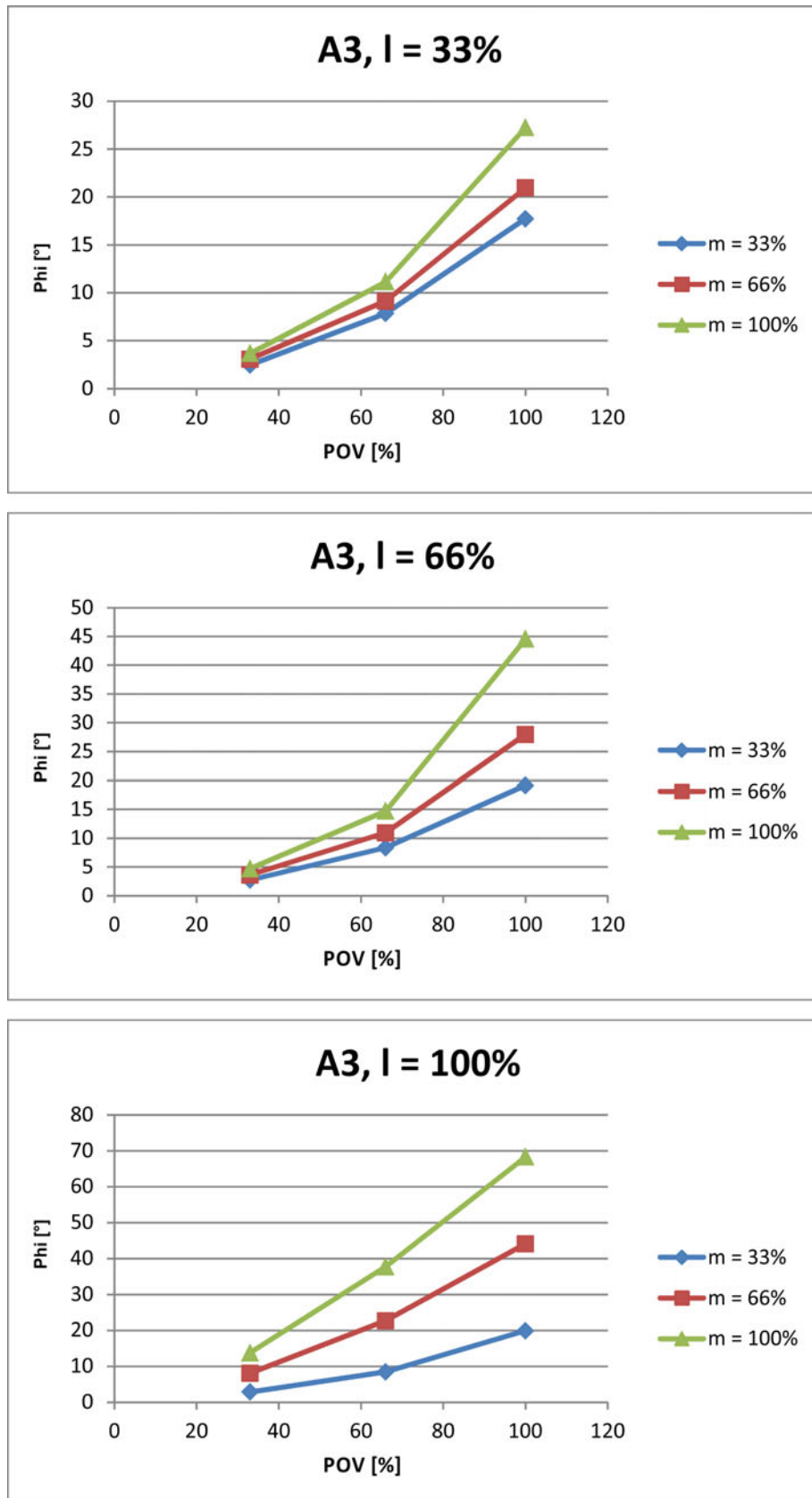

Fig. 4-22: Stopping distances for STOP 1, axis 3

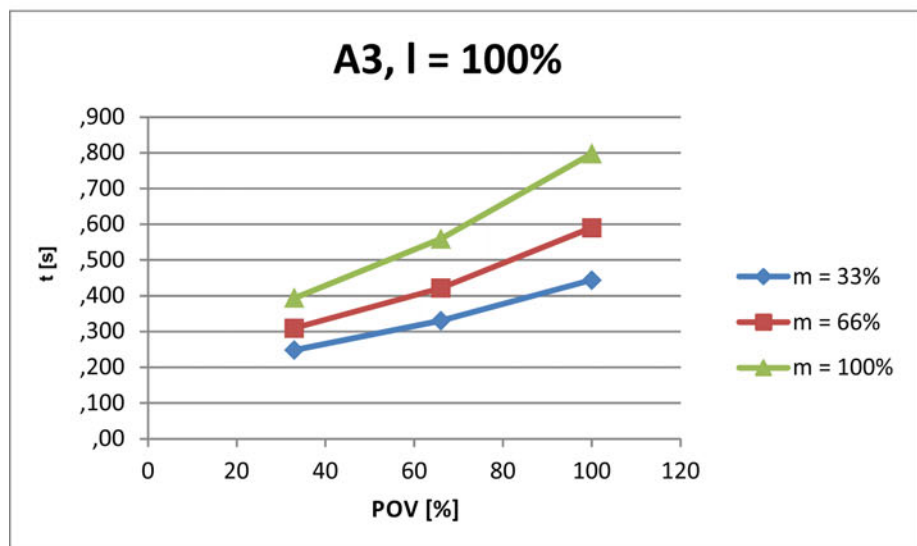
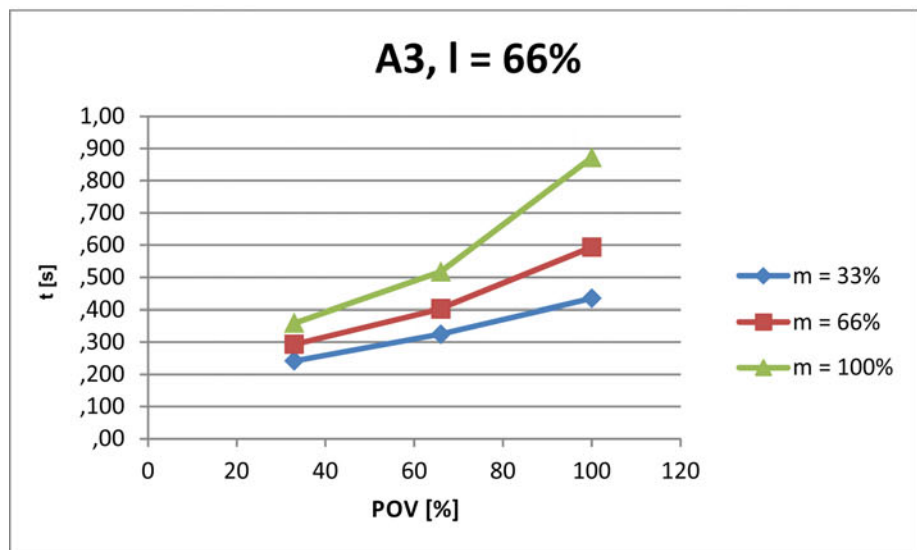
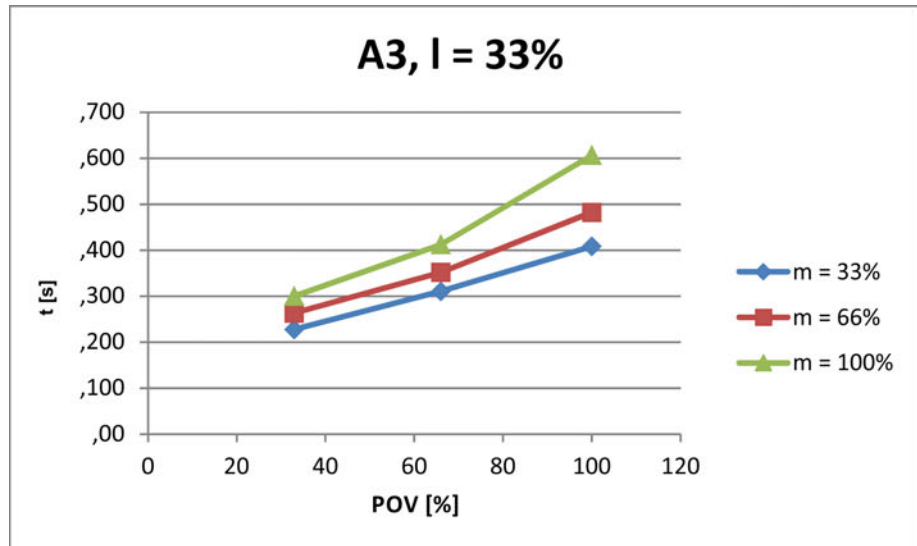

Fig. 4-23: Stopping times for STOP 1, axis 3

4.5.3.5 Stopping distances and stopping times for STOP 1, axis 4

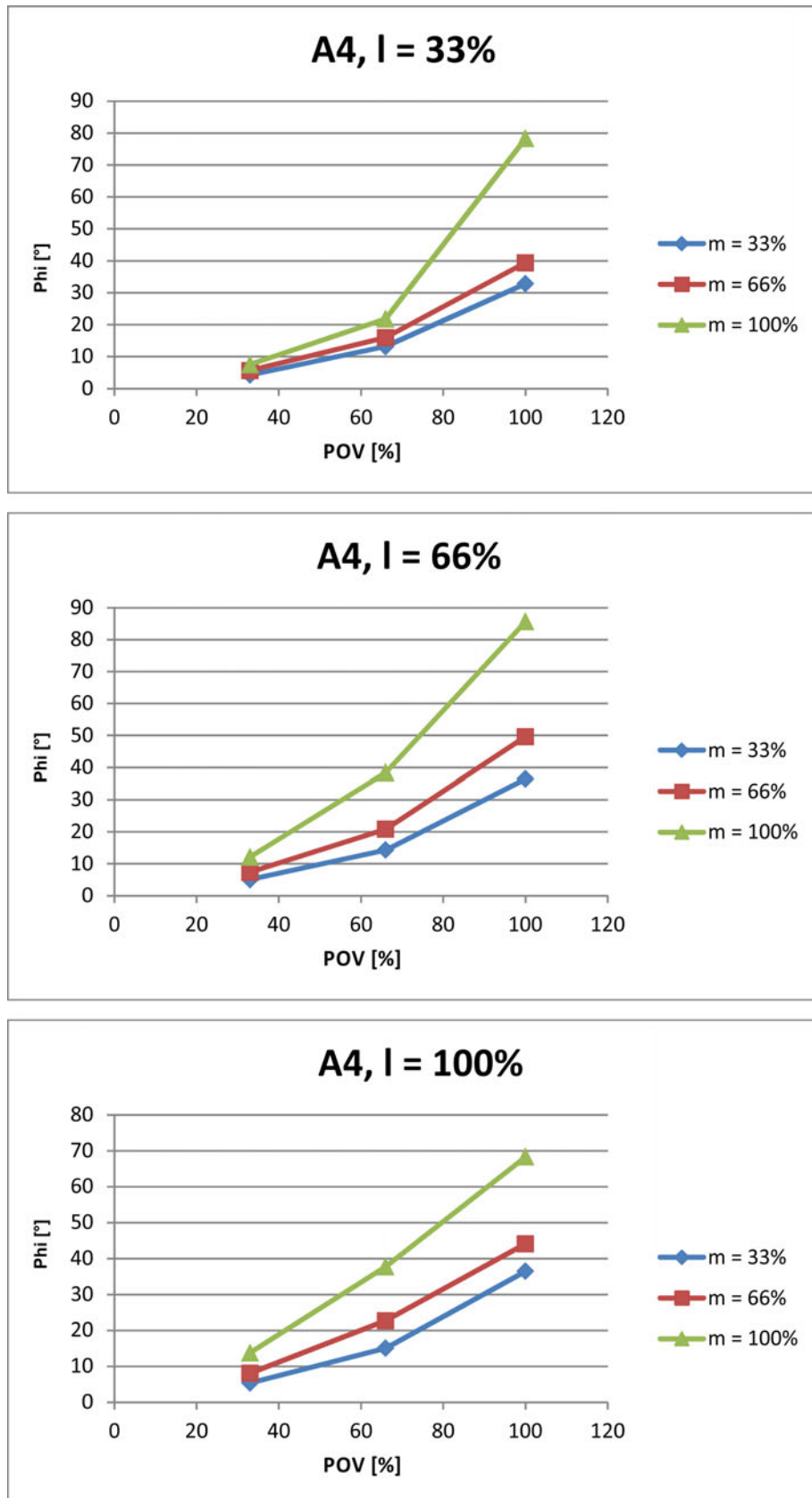

Fig. 4-24: Stopping distances for STOP 1, axis 4

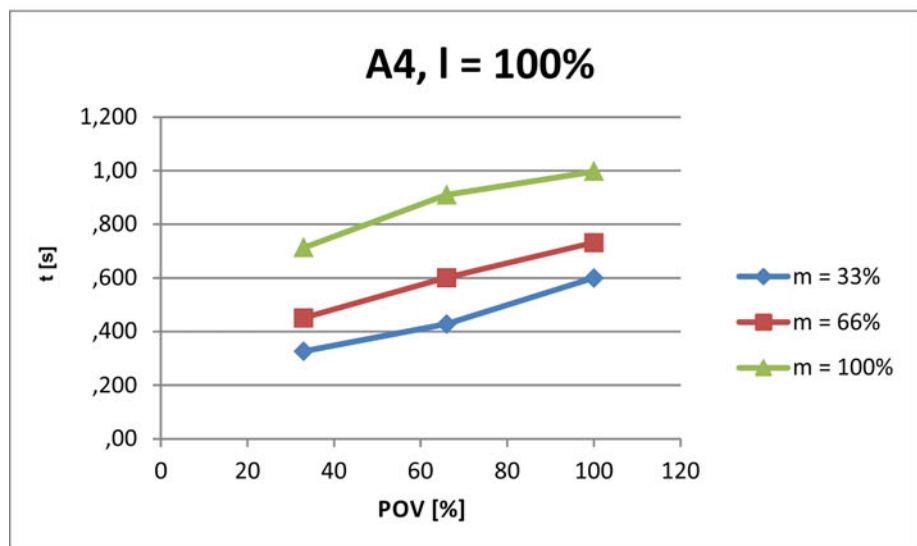
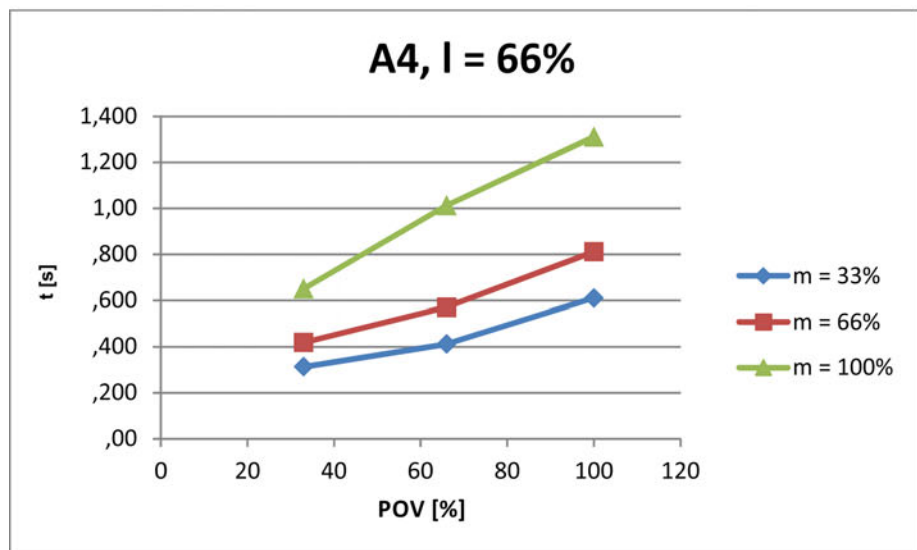
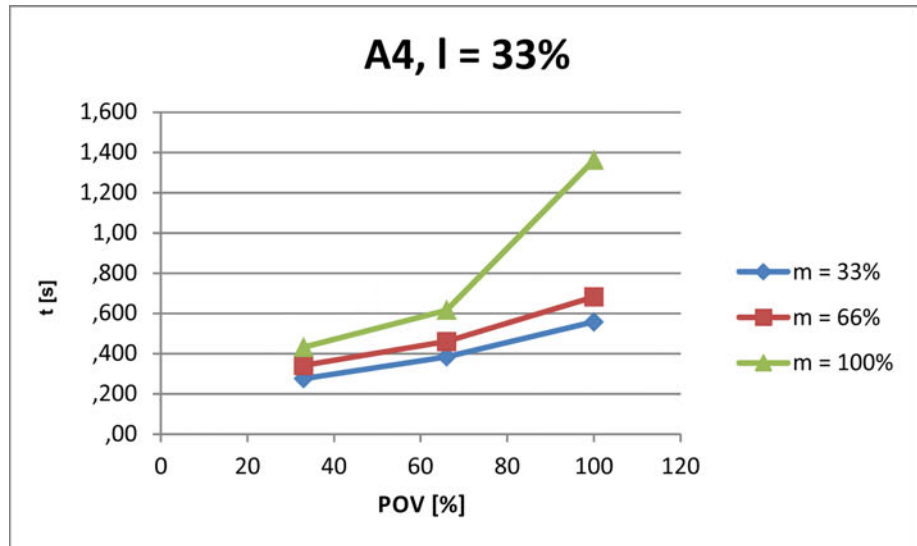

Fig. 4-25: Stopping times for STOP 1, axis 4

4.5.4 Stopping distances and stopping times for LBR iiwa 14 R820

The stopping distances and stopping times indicated apply to the following media flange:

- Basic flange



The stopping distances and times of other media flanges are specified in the media flange assembly and operating instructions.

4.5.4.1 Stopping distances and stopping times for STOP 0, axis 1 to axis 4

The table shows the stopping distances and stopping times after a STOP 0 (category 0 stop) is triggered. The values refer to the following configuration:

- Extension l = 100%
- Program override POV = 100%
- Mass m = maximum load (rated load + supplementary load on arm)

	Stopping distance (°)	Stopping time (s)
Axis 1	5.742	0.188
Axis 2	5.998	0.200
Axis 3	9.323	0.198
Axis 4	3.162	0.092

4.5.4.2 Stopping distances and stopping times for STOP 1, axis 1

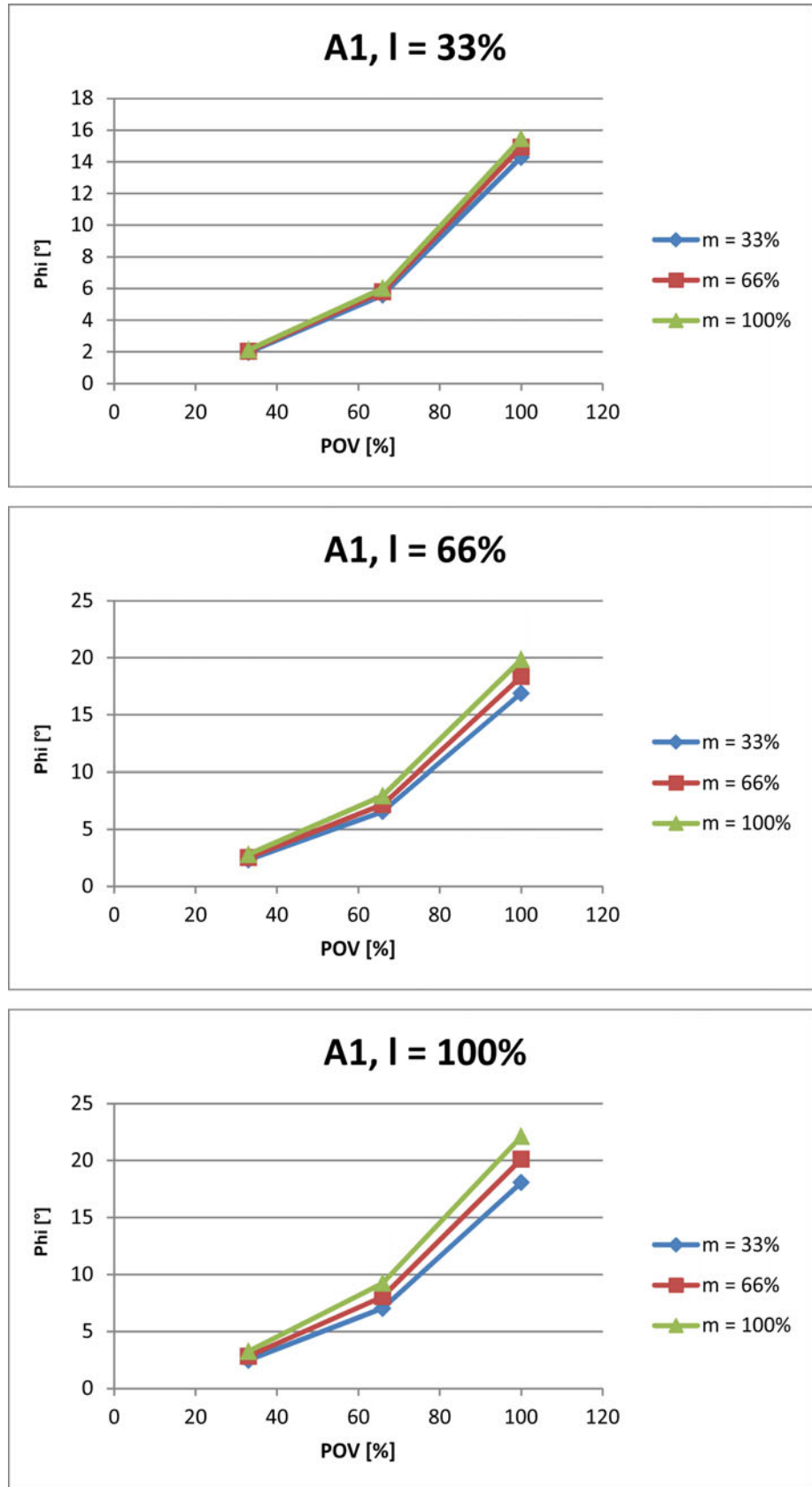

Fig. 4-26: Stopping distances for STOP 1, axis 1

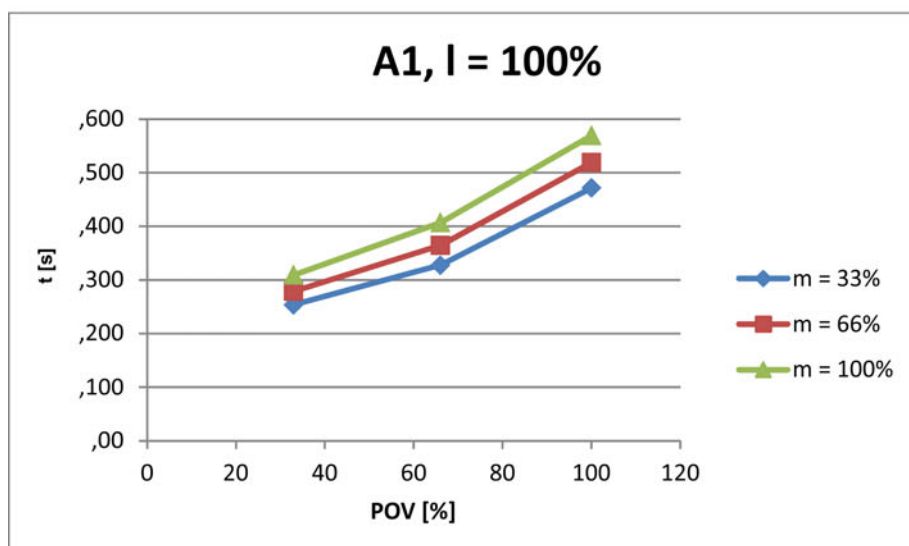
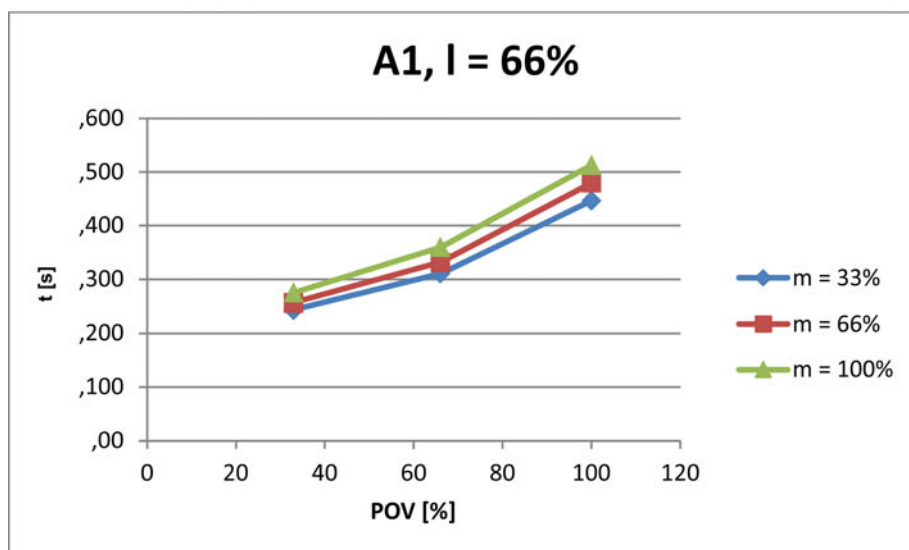
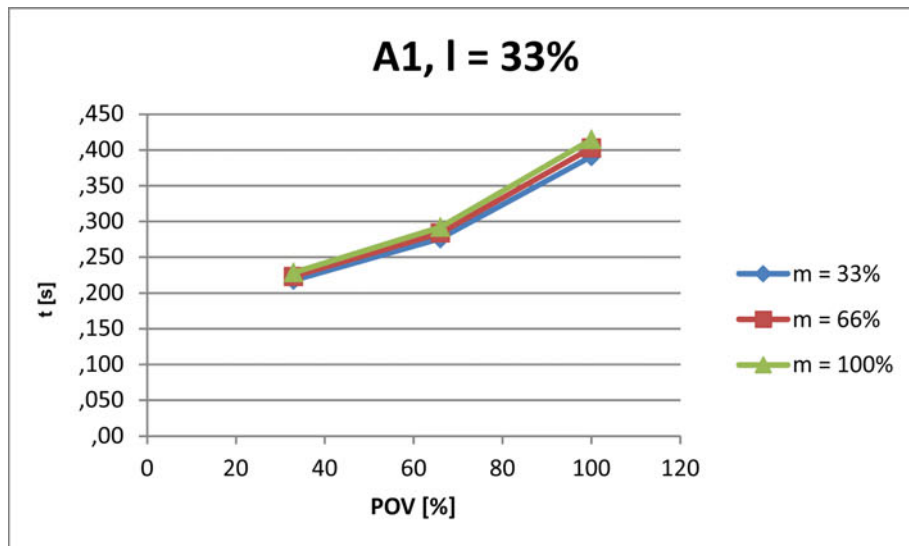

Fig. 4-27: Stopping times for STOP 1, axis 1

4.5.4.3 Stopping distances and stopping times for STOP 1, axis 2

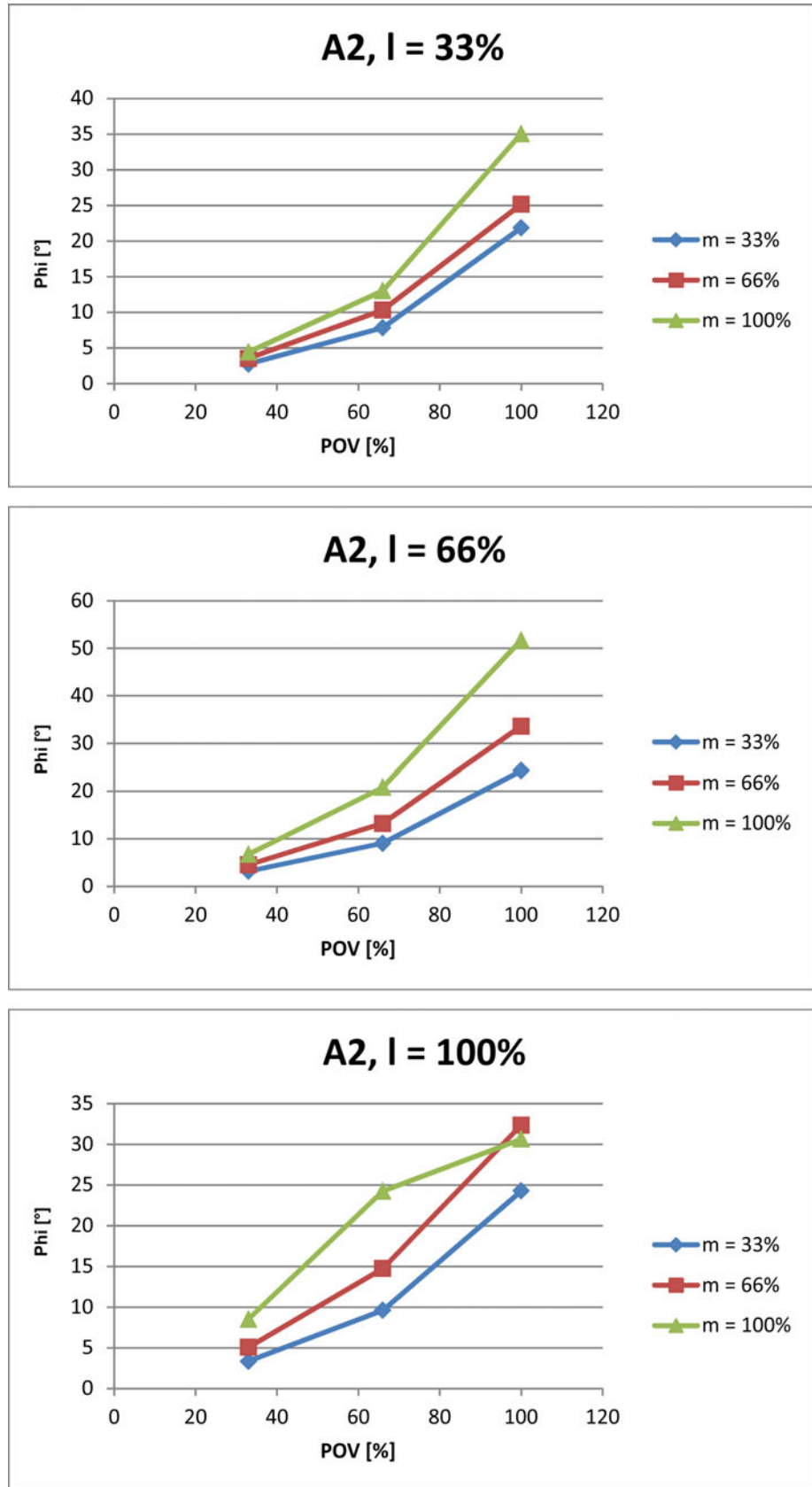

Fig. 4-28: Stopping distances for STOP 1, axis 2

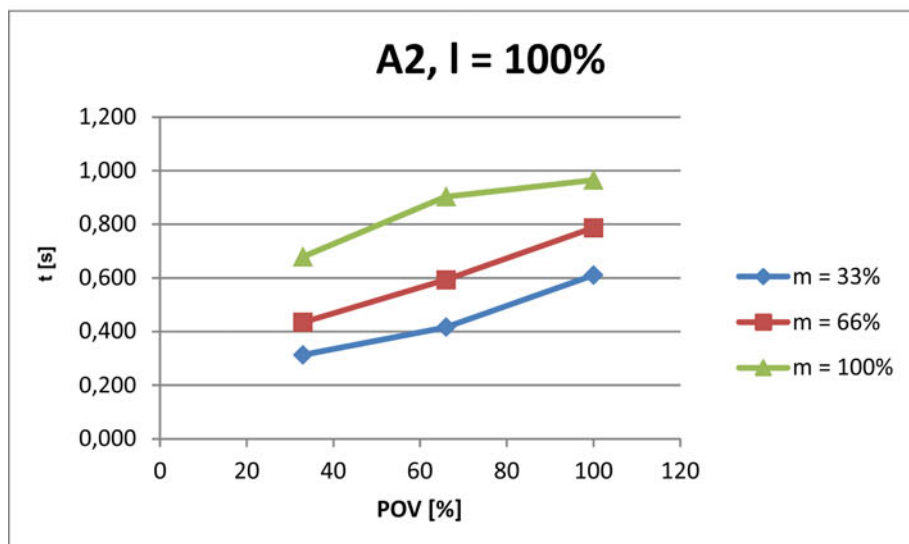
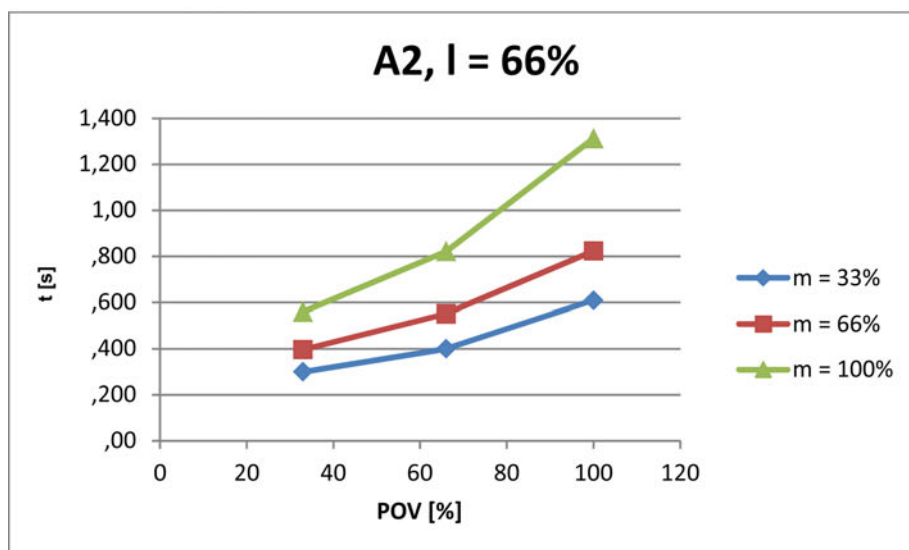
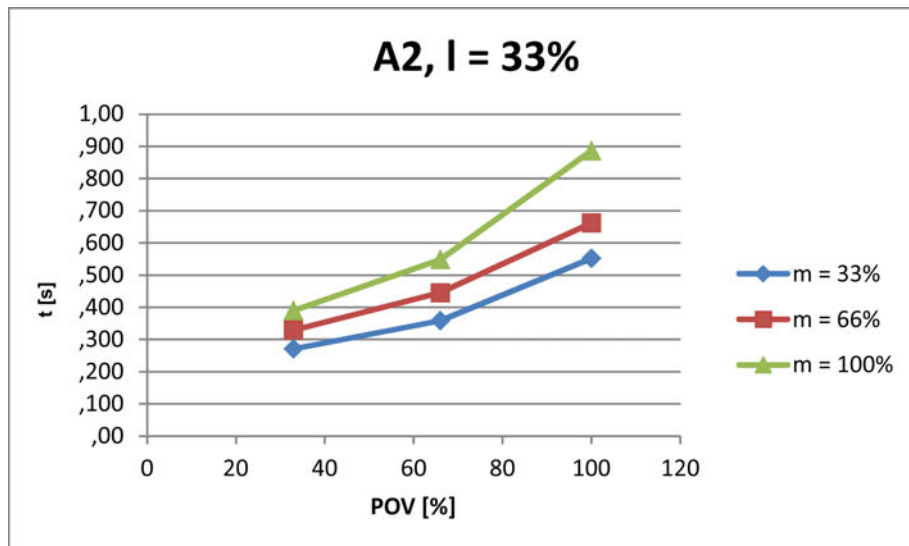

Fig. 4-29: Stopping times for STOP 1, axis 2

4.5.4.4 Stopping distances and stopping times for STOP 1, axis 3

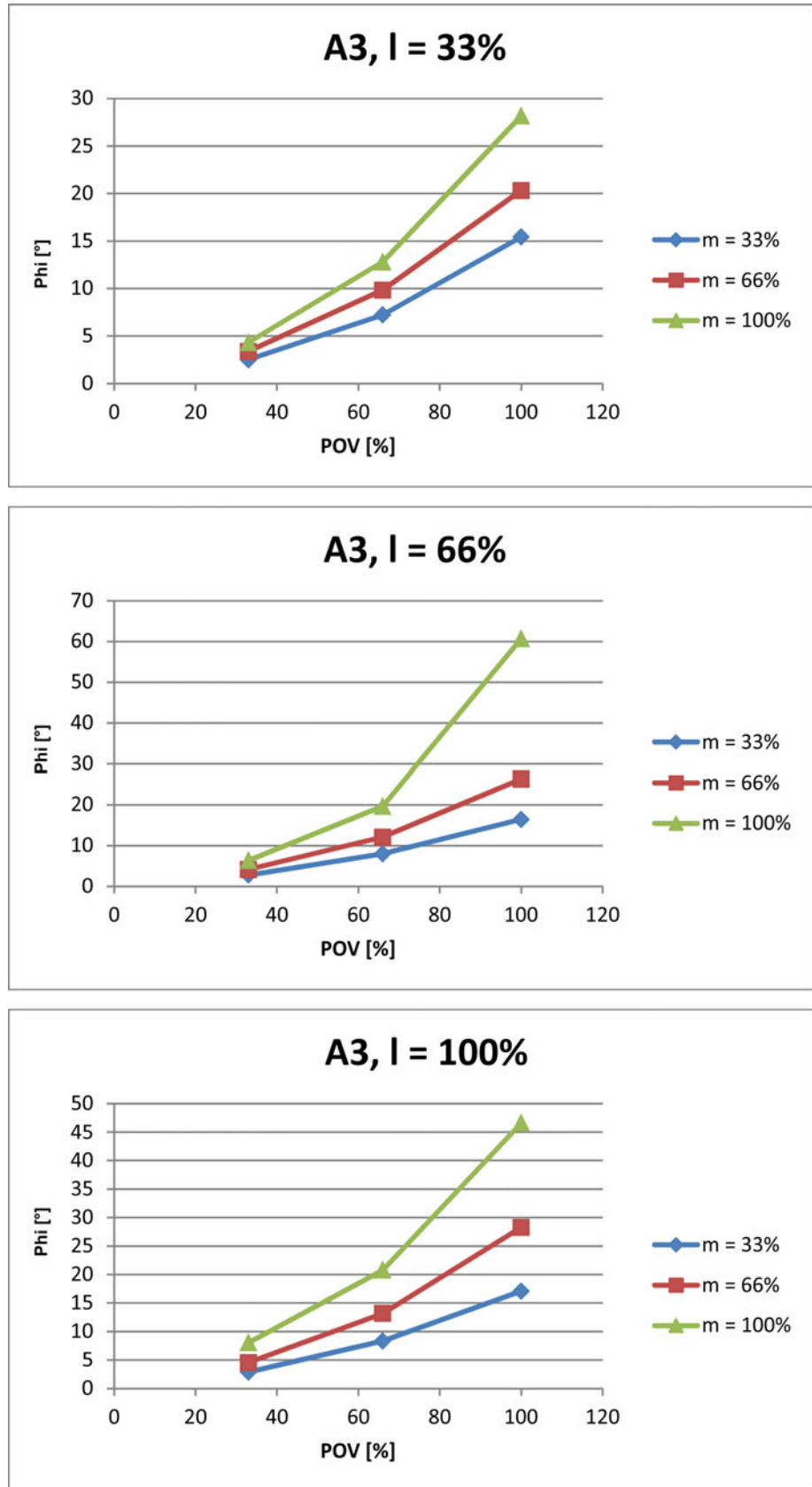

Fig. 4-30: Stopping distances for STOP 1, axis 3

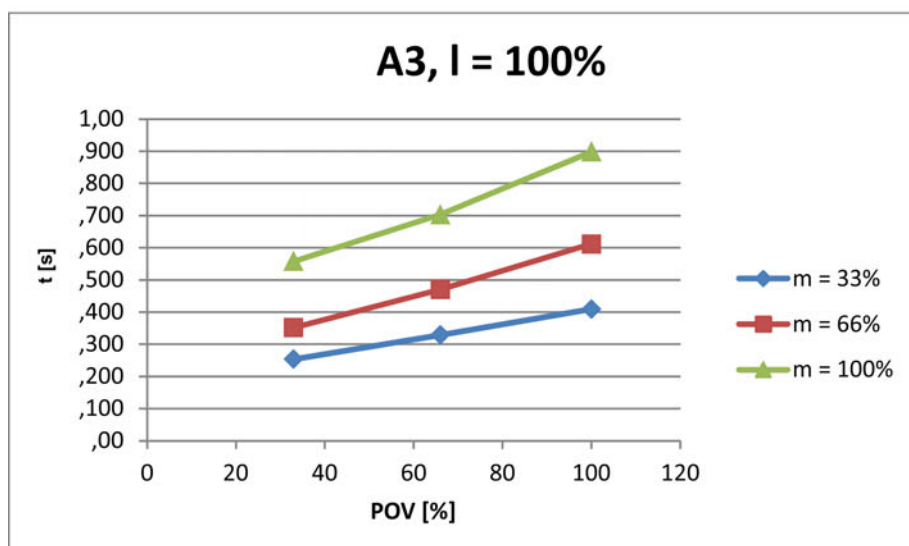
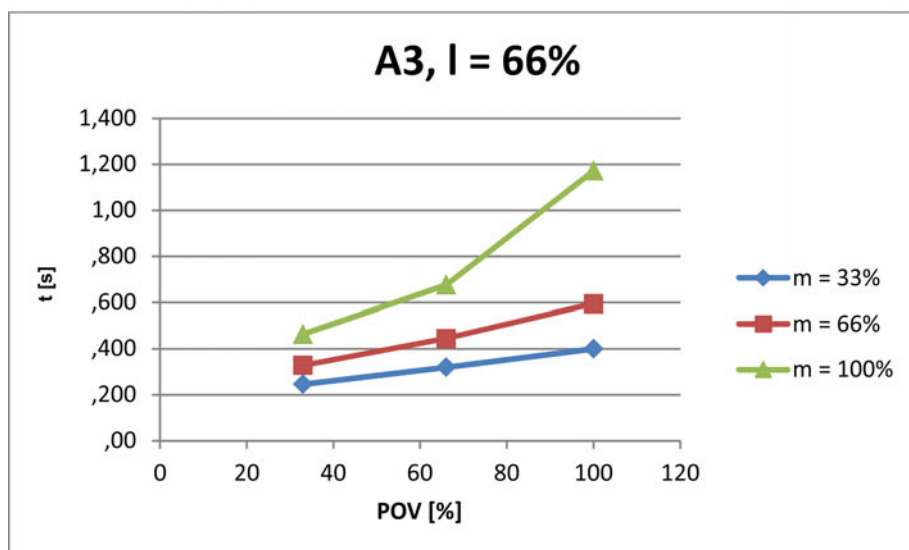
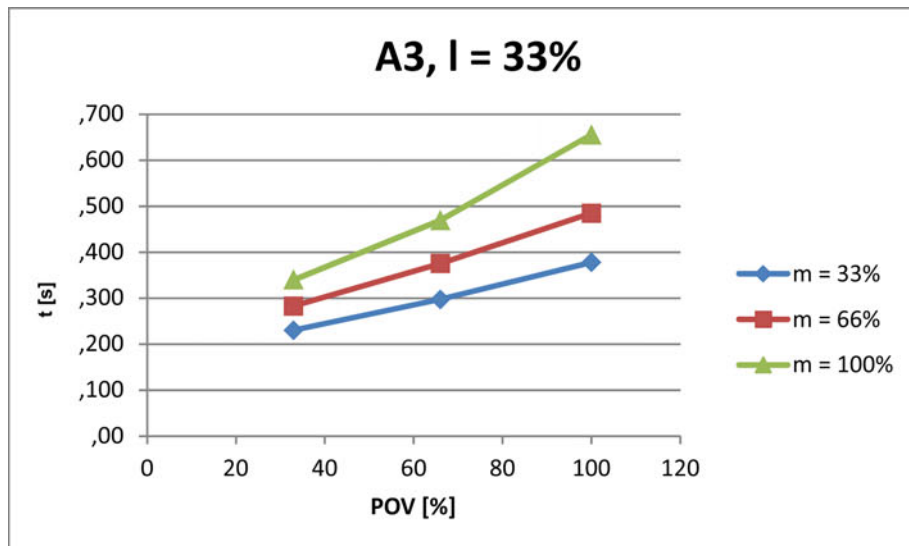

Fig. 4-31: Stopping times for STOP 1, axis 3

4.5.4.5 Stopping distances and stopping times for STOP 1, axis 4

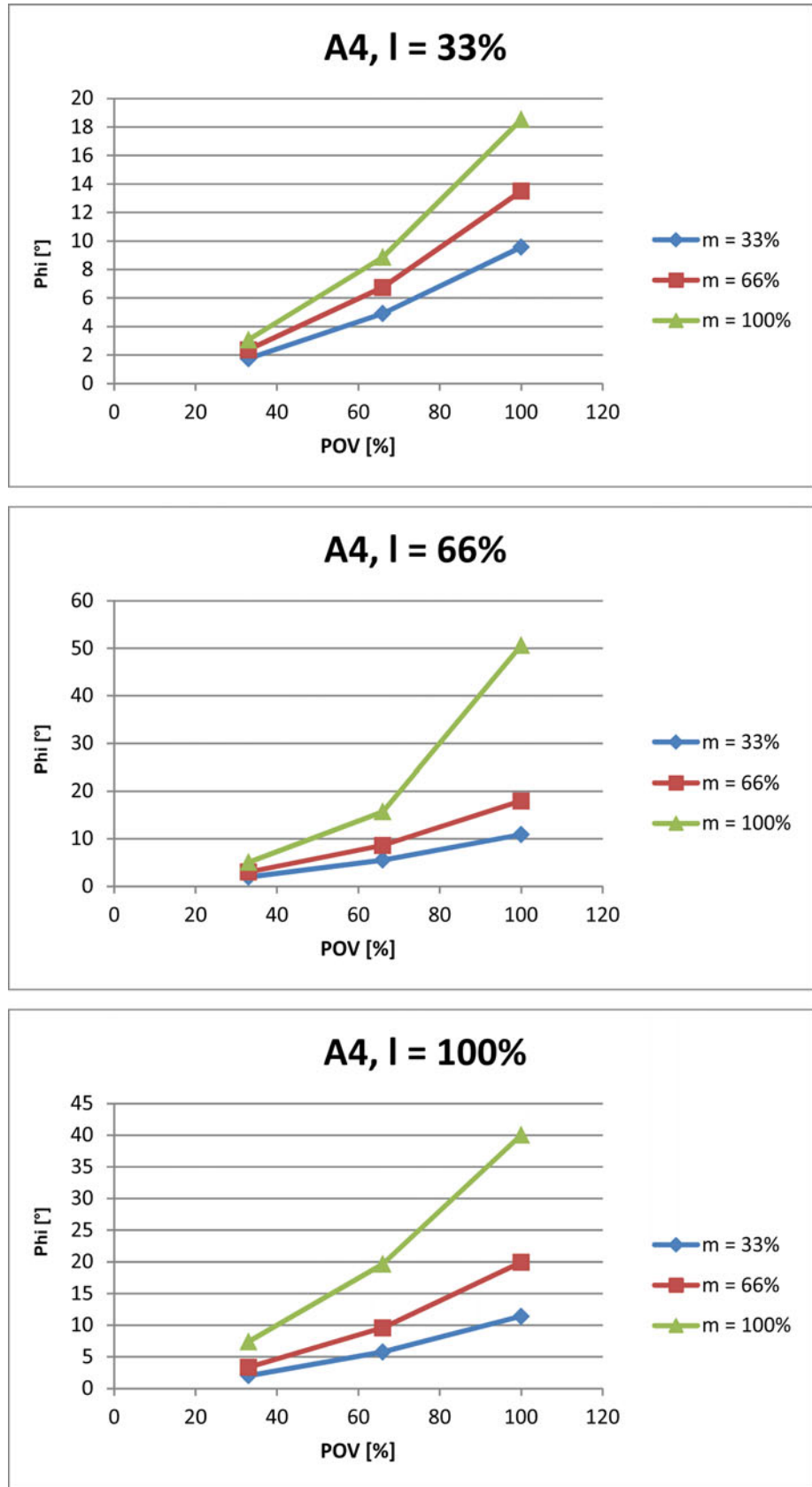

Fig. 4-32: Stopping distances for STOP 1, axis 4

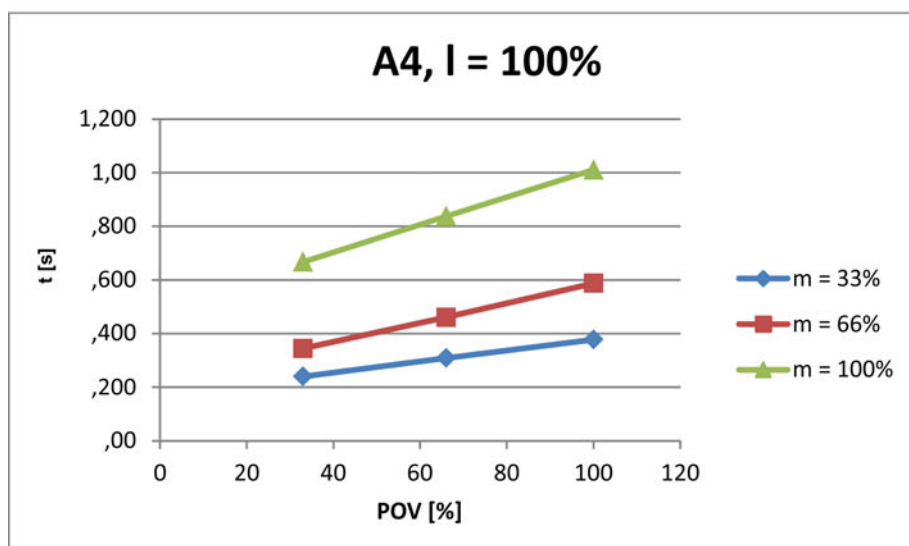
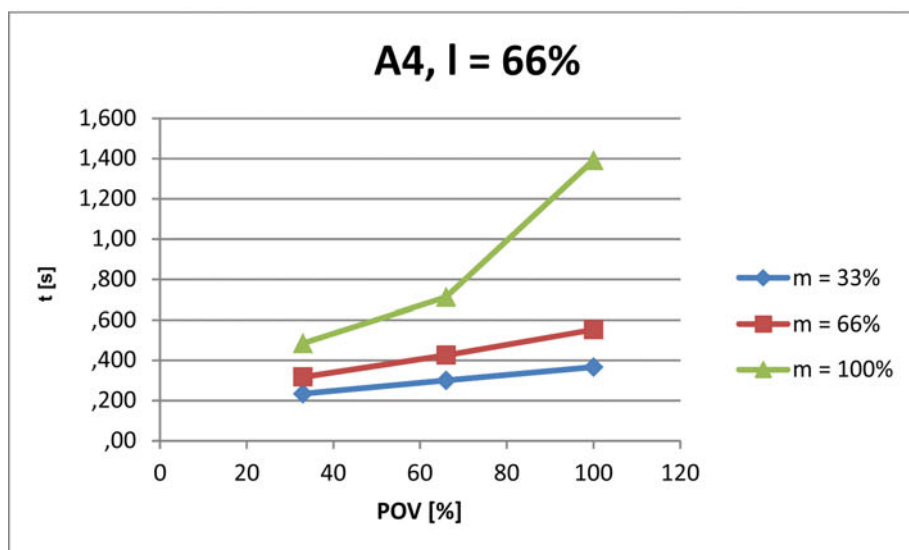
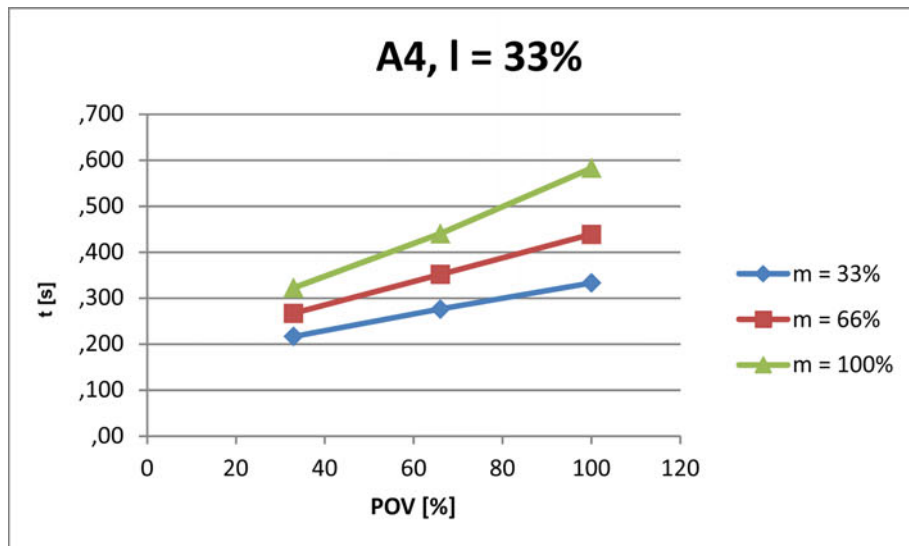

Fig. 4-33: Stopping times for STOP 1, axis 4

5 Safety

5.1 Legal framework

5.1.1 Liability

The device described in this document is either an industrial robot or a component thereof.

Components of the industrial robot:

- Manipulator
- Robot controller
- Hand-held control panel
- Connecting cables
- Software
- Options, accessories

The industrial robot is built using state-of-the-art technology and in accordance with the recognized safety rules. Nevertheless, misuse of the industrial robot may constitute a risk to life and limb or cause damage to the industrial robot and to other material property.

The industrial robot may only be used in perfect technical condition in accordance with its designated use and only by safety-conscious persons who are fully aware of the risks involved in its operation. Use of the industrial robot is subject to compliance with this document and with the declaration of incorporation supplied together with the industrial robot. Any functional disorders affecting safety must be rectified immediately.

Safety information

Safety information cannot be held against KUKA Roboter GmbH. Even if all safety instructions are followed, this is not a guarantee that the industrial robot will not cause personal injuries or material damage.

No modifications may be carried out to the industrial robot without the authorization of KUKA Roboter GmbH. Additional components (tools, software, etc.), not supplied by KUKA Roboter GmbH, may be integrated into the industrial robot. The user is liable for any damage these components may cause to the industrial robot or to other material property.

In addition to the Safety chapter, this document contains further safety instructions. These must also be observed.

5.1.2 Intended use of the industrial robot

The industrial robot is intended exclusively for the use designated in the "Purpose" chapter of the operating instructions or assembly instructions.

Any use or application deviating from the intended use is deemed to be misuse and is not allowed. The manufacturer is not liable for any damage resulting from such misuse. The risk lies entirely with the user.

Operation of the industrial robot in accordance with its intended use also requires compliance with the operating and assembly instructions for the individual components, with particular reference to the maintenance specifications.

The user is responsible for the performance of a risk analysis. This indicates the additional safety equipment that is required, the installation of which is also the responsibility of the user.

Misuse

Any use or application deviating from the intended use is deemed to be misuse and is not allowed. This includes e.g.:

- Transportation of persons and animals
- Use as a climbing aid
- Operation outside the specified operating parameters
- Use in potentially explosive environments
- Operation without the required additional safety equipment
- Outdoor operation
- Underground operation

5.1.3 EC declaration of conformity and declaration of incorporation

The industrial robot constitutes partly completed machinery as defined by the EC Machinery Directive. The industrial robot may only be put into operation if the following preconditions are met:

- The industrial robot is integrated into a complete system.
or: The industrial robot, together with other machinery, constitutes a complete system.
or: All safety functions and safeguards required for operation in the complete machine as defined by the EC Machinery Directive have been added to the industrial robot.
- The complete system complies with the EC Machinery Directive. This has been confirmed by means of an assessment of conformity.

Declaration of conformity

The system integrator must issue a declaration of conformity for the complete system in accordance with the Machinery Directive. The declaration of conformity forms the basis for the CE mark for the system. The industrial robot must always be operated in accordance with the applicable national laws, regulations and standards.

The robot controller is CE certified under the EMC Directive and the Low Voltage Directive.

Declaration of incorporation

The partly completed machinery is supplied with a declaration of incorporation in accordance with Annex II B of the EC Machinery Directive 2006/42/EC. The assembly instructions and a list of essential requirements complied with in accordance with Annex I are integral parts of this declaration of incorporation.

The declaration of incorporation declares that the start-up of the partly completed machinery is not allowed until the partly completed machinery has been incorporated into machinery, or has been assembled with other parts to form machinery, and this machinery complies with the terms of the EC Machinery Directive, and the EC declaration of conformity is present in accordance with Annex II A.

5.2 Safety functions

Safety functions are distinguished according to the safety requirements that they fulfill:

- Safety-oriented functions for the protection of personnel
The safety-oriented functions of the industrial robot meet the following safety requirements:
 - **Category 3** and **Performance Level d** in accordance with EN ISO 13849-1
 - **SIL 2** according to EN 62061

The requirements are only met on the following condition, however:

- All safety-relevant mechanical and electromechanical components of the industrial robot are tested for correct functioning during start-up

and at least once every 12 months, unless otherwise determined in accordance with a workplace risk assessment. These include:

- EMERGENCY STOP device on the smartPAD
- Enabling device on the smartPAD
- Enabling device on the media flange Touch (if present)
- Keyswitch on the smartPAD
- Safe outputs of the discrete safety interface
- Non-safety-oriented functions for the protection of machines

The non-safety-oriented functions of the industrial robot do not meet specific safety requirements:

 **DANGER** In the absence of the required operational safety functions and safeguards, the industrial robot can cause personal injury or material damage. If the required safety functions or safeguards are dismantled or deactivated, the industrial robot may not be operated.

 During system planning, the safety functions of the overall system must also be planned and designed. The industrial robot must be integrated into this safety system of the overall system.

5.2.1 Terms used

Term	Description
Axis range	Range within which the axis may move The axis range must be defined for each axis.
Stopping distance	Stopping distance = reaction distance + braking distance The stopping distance is part of the danger zone.
Workspace	The manipulator is allowed to move within its workspace. The workspace is derived from the individual axis ranges.
Automatic (AUT)	Operating mode for program execution. The manipulator moves at the programmed velocity.
Operator (User)	The user of the industrial robot can be the management, employer or delegated person responsible for use of the industrial robot.
Danger zone	The danger zone consists of the workspace and the stopping distances.
Service life	The service life of a safety-relevant component begins at the time of delivery of the component to the customer. The service life is not affected by whether the component is used in a robot controller or elsewhere or not, as safety-relevant components are also subject to aging during storage.
CRR	Controlled Robot Retraction CRR is an operating mode which can be selected when the industrial robot is stopped by the safety controller for one of the following reasons: <ul style="list-style-type: none"> ■ Industrial robot violates an axis-specific or Cartesian monitoring space. ■ Orientation of a safety-oriented tool is outside the monitored range. ■ Industrial robot violates a force or torque monitoring function. ■ A position sensor is not mastered or referenced. ■ A joint torque sensor is not referenced. After changing to CRR mode, the industrial robot may once again be moved.

Term	Description
KUKA smartPAD	See "smartPAD"
Manipulator	The robot arm and the associated electrical installations
Safety zone	The manipulator is not allowed to move within the safety zone. The safety zone is the area outside the danger zone.
Safety stop	<p>The safety stop is triggered by the safety controller, interrupts the work procedure and causes all robot motions to come to a standstill. The program data are retained in the case of a safety stop and the program can be resumed from the point of interruption.</p> <p>The safety stop can be executed as a Stop category 0, Stop category 1 or Stop category 1 (path-maintaining).</p> <p>Note: In this document, a safety stop of Stop category 0 is referred to as safety stop 0, a safety stop of Stop category 1 as safety stop 1 and a safety stop of Stop category 1 (path-maintaining) as safety stop 1 (path-maintaining).</p>
smartPAD	The smartPAD is the hand-held control panel for the robot cell (station). It has all the operator control and display functions required for operation of the station.
Stop category 0	The drives are deactivated immediately and the brakes are applied.
Stop category 1	<p>The manipulator is braked and does not stay on the programmed path. The manipulator is brought to a standstill with the drives. As soon as an axis is at a standstill, the drive is switched off and the brake is applied.</p> <p>The internal electronic drive system of the robot performs safety-oriented monitoring of the braking process. Stop category 0 is executed in the event of a fault.</p> <p>Note: Stop category 1 is currently only supported by the LBR iiwa. For other manipulators, Stop category 0 is executed.</p>
Stop category 1 (path-maintaining)	<p>The manipulator is braked and stays on the programmed path. At standstill, the drives are deactivated and the brakes are applied.</p> <p>If Stop category 1 (path-maintaining) is triggered by the safety controller, the safety controller monitors the braking process. The brakes are applied and the drives are switched off after 1 s at the latest. Stop category 1 is executed in the event of a fault.</p>
System integrator (plant integrator)	System integrators are people who safely integrate the industrial robot into a complete system and commission it.
T1	<p>Test mode, Manual Reduced Velocity (≤ 250 mm/s)</p> <p>Note: With manual guidance in T1, the velocity is not reduced, but rather limited through a safety-oriented velocity monitoring in accordance with the safety configuration.</p> <p>Note: The maximum velocity of 250 mm/s does not apply to a mobile platform.</p>
T2	Test mode, Manual High Velocity (> 250 mm/s permissible)

5.2.2 Personnel

The following persons or groups of persons are defined for the industrial robot:

- User
- Personnel



All persons working with the industrial robot must have read and understood the industrial robot documentation, including the safety chapter.

User The user must observe the labor laws and regulations. This includes e.g.:

- The user must comply with his monitoring obligations.
- The user must carry out briefing at defined intervals.

Personnel Personnel must be instructed, before any work is commenced, in the type of work involved and what exactly it entails as well as any hazards which may exist. Instruction must be carried out regularly. Instruction is also required after particular incidents or technical modifications.

Personnel includes:

- System integrator
- Operators, subdivided into:
 - Start-up, maintenance and service personnel
 - Operating personnel
 - Cleaning personnel



Installation, exchange, adjustment, operation, maintenance and repair must be performed only as specified in the operating or assembly instructions for the relevant component of the industrial robot and only by personnel specially trained for this purpose.

System integrator The industrial robot is safely integrated into a complete system by the system integrator.

The system integrator is responsible for the following tasks:

- Installing the industrial robot
- Connecting the industrial robot
- Performing risk assessment
- Implementing the required safety functions and safeguards
- Issuing the declaration of conformity
- Attaching the CE mark
- Creating the operating instructions for the complete system

Operator The operator must meet the following preconditions:

- The operator must be trained for the work to be carried out.
- Work on the industrial robot must only be carried out by qualified personnel. These are people who, due to their specialist training, knowledge and experience, and their familiarization with the relevant standards, are able to assess the work to be carried out and detect any potential hazards.



Work on the electrical and mechanical equipment of the manipulator may only be carried out by KUKA Roboter GmbH.

5.2.3 Workspace, safety zone and danger zone

Working zones are to be restricted to the necessary minimum size in order to prevent danger to persons or the risk of material damage. Safe axis range limitations required for personnel protection are configurable.



Further information about configuring safe axis range limitations is contained in the "Safety configuration" chapter of the operating and programming instructions.

The danger zone consists of the workspace and the stopping distances of the manipulator. In the event of a stop, the manipulator is braked and comes to a

stop within the danger zone. The safety zone is the area outside the danger zone.

The danger zone must be protected by means of physical safeguards, e.g. by light barriers, light curtains or safety fences. If there are no physical safeguards present, the requirements for collaborative operation in accordance with EN ISO 10218 must be met. There must be no shearing or crushing hazards at the loading and transfer areas.

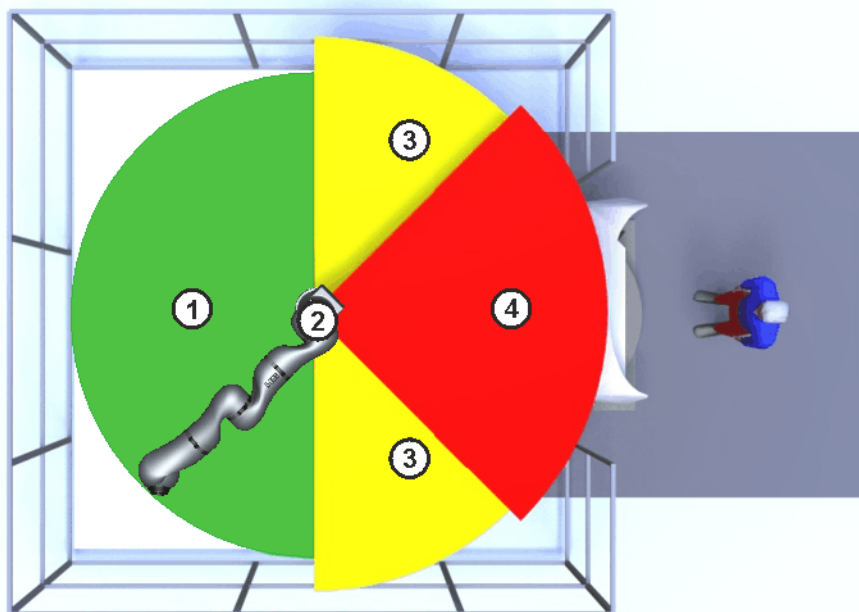

Fig. 5-1: Example: axis range A1

- | | | | |
|---|-------------|---|-------------------|
| 1 | Workspace | 3 | Stopping distance |
| 2 | Manipulator | 4 | Safety zone |

5.2.4 Safety-oriented functions

The following safety-oriented functions are present and permanently defined in the industrial robot:

- EMERGENCY STOP device
- Enabling device
- Locking of the operating mode (by means of a keyswitch)

The following safety-oriented functions are preconfigured and can be integrated into the system via the safety interface of the robot controller:

- Operator safety (= connection for the monitoring of physical safeguards)
- External EMERGENCY STOP device
- External safety stop 1 (path-maintaining)

Other safety-oriented functions may be configured, e.g.:

- External enabling device
- External safe operational stop
- Axis-specific workspace monitoring
- Cartesian workspace monitoring
- Cartesian protected space monitoring
- Velocity monitoring

- Standstill monitoring
- Axis torque monitoring
- Collision detection



Further information about configuring the safety functions is contained in the "Safety configuration" chapter of the operating and programming instructions.

The preconfigured safety functions are described in the following sections on safety.

5.2.4.1 EMERGENCY STOP device

The EMERGENCY STOP device for the industrial robot is the EMERGENCY STOP device on the smartPAD. The device must be pressed in the event of a hazardous situation or emergency.

Reaction of the industrial robot if the EMERGENCY STOP device is pressed:

- The manipulator stops with a safety stop 1 (path-maintaining).

Before operation can be resumed, the EMERGENCY STOP device must be turned to release it.



WARNING Tools and other equipment connected to the manipulator must be integrated into the EMERGENCY STOP circuit on the system side if they could constitute a potential hazard. Failure to observe this precaution may result in death, severe injuries or considerable damage to property.

If a holder is used for the smartPAD and conceals the EMERGENCY STOP device on the smartPAD, an external EMERGENCY STOP device must be installed that is accessible at all times.

(>>> 5.2.4.4 "External EMERGENCY STOP device" Page 52)

5.2.4.2 Enabling device

The enabling devices of the industrial robot are the enabling switches on the smartPAD.

There are 3 enabling switches installed on the smartPAD. The enabling switches have 3 positions:

- Not pressed
- Center position
- Fully pressed (panic position)

In the test modes and in CRR, the manipulator can only be moved if one of the enabling switches is held in the central position.

- Releasing the enabling switch triggers a safety stop 1 (path-maintaining).
- Fully pressing the enabling switch triggers a safety stop 1 (path-maintaining).
- It is possible to hold 2 enabling switches in the center position simultaneously for several seconds. This makes it possible to adjust grip from one enabling switch to another one. If 2 enabling switches are held simultaneously in the center position for longer than 15 seconds, this triggers a safety stop 1.

If an enabling switch malfunctions (e.g. jams in the central position), the industrial robot can be stopped using the following methods:

- Press the enabling switch down fully.

- Actuate the EMERGENCY STOP device.
- Release the Start key.

**WARNING**

The enabling switches must not be held down by adhesive tape or other means or tampered with in any other way.
Death, injuries or damage to property may result.

5.2.4.3 “Operator safety” signal

The “operator safety” signal is used for monitoring physical safeguards, e.g. safety gates. In the default configuration, T2 and automatic operation are not possible without this signal. Alternatively, the requirements for collaborative operation in accordance with EN ISO 10218 must be met.

Reaction of the industrial robot in the event of a loss of signal during T2 or automatic operation (default configuration):

- The manipulator stops with a safety stop 1 (path-maintaining).

By default, operator safety is not active in the modes T1 (Manual Reduced Velocity) and CRR, i.e. the signal is not evaluated.

**WARNING**

Following a loss of signal, automatic operation must not be resumed merely by closing the safeguard; the signal for operator safety must first be set by an additional device, e.g. by an acknowledge button. It is the responsibility of the system integrator to ensure this. This is to prevent automatic operation from being resumed inadvertently while there are still persons in the danger zone, e.g. due to the safety gate closing accidentally.

- This additional device must be designed in such a way that an actual check of the danger zone can be carried out first. Devices that do not allow this (e.g. because they are automatically triggered by closure of the safeguard) are not permitted.
- Failure to observe this may result in death to persons, severe injuries or considerable damage to property.

5.2.4.4 External EMERGENCY STOP device

Every operator station that can initiate a robot motion or other potentially hazardous situation must be equipped with an EMERGENCY STOP device. The system integrator is responsible for ensuring this.

Reaction of the industrial robot if the external EMERGENCY STOP device is pressed (default configuration):

- The manipulator stops with a safety stop 1 (path-maintaining).

External EMERGENCY STOP devices are connected via the safety interface of the robot controller. External EMERGENCY STOP devices are not included in the scope of supply of the industrial robot.

5.2.4.5 External safety stop 1 (path-maintaining)

The external safety stop 1 (path-maintaining) can be triggered via an input on the safety interface (default configuration). The state is maintained as long as the external signal is FALSE. If the external signal is TRUE, the manipulator can be moved again. No acknowledgement is required.

5.2.4.6 External enabling device

External enabling devices are required if it is necessary for more than one person to be in the danger zone of the industrial robot.

Multiple external enabling devices can be connected via the safety interface of the robot controller. External enabling devices are not included in the scope of supply of the industrial robot.

An external enabling device can be used for manual guidance of the robot. When enabling is active, the robot may only be moved at reduced velocity.

For manual guidance, safety-oriented velocity monitoring with a maximum permissible velocity of 250 mm/s is preconfigured. The maximum permissible velocity can be adapted.

The value for the maximum permissible velocity must be determined as part of a risk assessment.

5.2.4.7 External safe operational stop

The safe operational stop is a standstill monitoring function. It does not stop the robot motion, but monitors whether the robot axes are stationary.

The safe operational stop can be triggered via an input on the safety interface. The state is maintained as long as the external signal is FALSE. If the external signal is TRUE, the manipulator can be moved again. No acknowledgement is required.

5.2.5 Triggers for safety-oriented stop reactions

Stop reactions are triggered in response to operator actions or as a reaction to monitoring functions and errors. The following tables show the different stop reactions according to the operating mode that has been set.

Overview

In KUKA Sunrise a distinction is made between the following triggers:

- Permanently defined triggers

Permanently defined triggers for stop reactions and the associated stop category are preset by the system and cannot be changed. However, it is possible for the implemented stop reaction to be stepped up in the user-specific safety configuration.
- User-specific triggers

In addition to the permanently defined triggers, the user can also configure other triggers for stop reactions including the associated stop category.



Further information about configuring the safety functions is contained in the "Safety configuration" chapter of the operating and programming instructions.

Permanently defined triggers

The following triggers for stop reactions are permanently defined:

Trigger	T1, T2, CRR	AUT
Operating mode changed during operation	Safety stop 1 (path-maintaining)	
Enabling switch released	Safety stop 1 (path-maintaining)	-
Enabling switch pressed fully down (panic position)	Safety stop 1 (path-maintaining)	-
Local E-STOP pressed	Safety stop 1 (path-maintaining)	
Error in safety controller	Safety stop 1	

User-specific triggers

The robot controller is shipped with a safety configuration that is active on initial start-up. This contains the following user-specific stop reaction triggers preconfigured by KUKA (in addition to the permanently defined triggers).

Trigger	T1, CRR	T2, AUT
Safety gate opened (operator safety)	-	Safety stop 1 (path-maintaining)

When creating a new Sunrise project, the system automatically generates a project-specific safety configuration. This contains the following user-specific stop reaction triggers preconfigured by KUKA (in addition to the permanently defined triggers).

i When the Sunrise project is transferred to the robot controller, the factory-set safety configuration is overwritten by the project-specific safety configuration. This makes it necessary for the safety configuration to be activated.
 Further information about activating the safety configuration is contained in the “Safety configuration” chapter of the operating and programming instructions.

Trigger	T1, CRR	T2, AUT
Safety gate opened (operator safety)	-	Safety stop 1 (path-maintaining)
External E-STOP pressed	Safety stop 1 (path-maintaining)	
External safety stop	Safety stop 1 (path-maintaining)	

Triggers for manual guidance

If an enabling device is configured for manual guidance, the following additional triggers for stop reactions are permanently defined:

Trigger	T1, CRR	T2, AUT
Manual guidance enabling switch released	Safety stop 1 (path-maintaining)	-
Manual guidance enabling switch pressed fully down (panic position)	Safety stop 1 (path-maintaining)	-
Maximum permissible velocity exceeded while manual guidance enabling signal is set	Safety stop 1 (path-maintaining)	

A maximum permissible velocity of 250 mm/s is preconfigured for manual guidance. The maximum permissible velocity can be adapted.

The value for the maximum permissible velocity must be determined as part of a risk assessment.

5.2.6 Non-safety-oriented functions

5.2.6.1 Mode selection

The industrial robot can be operated in the following modes:

- Manual Reduced Velocity (T1)
- Manual High Velocity (T2)
- Automatic (AUT)
- Controlled robot retraction (CRR)

Operating mode	Use	Velocities
T1	Programming, teaching and testing of programs.	<ul style="list-style-type: none"> ■ Program verification: Reduced programmed velocity, maximum 250 mm/s ■ Manual mode: Jog velocity, maximum 250 mm/s ■ Manual guidance: No limitation of the velocity, but safety-oriented velocity monitoring in accordance with the safety configuration <p>Note: The maximum velocity of 250 mm/s does not apply to a mobile platform.</p>
T2	Testing of programs	<ul style="list-style-type: none"> ■ Program verification: Programmed velocity ■ Manual mode: Not possible
AUT	Automatic execution of programs For industrial robots with and without higher-level controllers	<ul style="list-style-type: none"> ■ Program mode: Programmed velocity ■ Manual mode: Not possible
CRR	<p>CRR is an operating mode which can be selected when the industrial robot is stopped by the safety controller for one of the following reasons:</p> <ul style="list-style-type: none"> ■ Industrial robot violates an axis-specific or Cartesian monitoring space. ■ Orientation of a safety-oriented tool is outside the monitored range. ■ Industrial robot violates a force or torque monitoring function. ■ A position sensor is not mastered or referenced. ■ A joint torque sensor is not referenced. <p>After changing to CRR mode, the industrial robot may once again be moved.</p>	<ul style="list-style-type: none"> ■ Program verification: Reduced programmed velocity, maximum 250 mm/s ■ Manual mode: Jog velocity, maximum 250 mm/s ■ Manual guidance: No limitation of the velocity, but safety-oriented velocity monitoring in accordance with the safety configuration

5.2.6.2 Software limit switches

The axis ranges of all manipulator axes are limited by means of non-safety-oriented software limit switches. These software limit switches only serve as machine protection and are preset in such a way that the manipulator is stopped under servo control if the axis limit is exceeded, thereby preventing damage to the mechanical equipment.

5.3 Additional protective equipment

5.3.1 Jog mode

In the operating modes T1 (Manual Reduced Velocity), T2 (Manual High Velocity) and CRR, the robot controller can only execute programs in jog mode. This means that it is necessary to hold down an enabling switch and the Start key in order to execute a program.

- Releasing the enabling switch on the smartPAD triggers a safety stop 1 (path-maintaining).
- Pressing fully down on the enabling switch on the smartPAD triggers a safety stop 1 (path-maintaining).
- Releasing the Start key triggers a stop of Stop category 1 (path-maintaining).

5.3.2 Labeling on the industrial robot

All plates, labels, symbols and marks constitute safety-relevant parts of the industrial robot. They must not be modified or removed.

Labeling on the industrial robot consists of:

- Identification plates
- Warning signs
- Safety symbols
- Designation labels
- Cable markings
- Rating plates

 Further information is contained in the technical data of the operating instructions or assembly instructions of the components of the industrial robot.

5.3.3 External safeguards

The access of persons to the danger zone of the industrial robot must be prevented by means of safeguards. Alternatively, the requirements for collaborative operation in accordance with EN ISO 10218 must be met. It is the responsibility of the system integrator to ensure this.

Physical safeguards must meet the following requirements:

- They meet the requirements of EN 953.
- They prevent access of persons to the danger zone and cannot be easily circumvented.
- They are sufficiently fastened and can withstand all forces that are likely to occur in the course of operation, whether from inside or outside the enclosure.
- They do not, themselves, represent a hazard or potential hazard.
- The prescribed minimum clearance from the danger zone is maintained.

Safety gates (maintenance gates) must meet the following requirements:

- They are reduced to an absolute minimum.
- The interlocks (e.g. safety gate switches) are linked to the configured operator safety inputs of the robot controller.

- Switching devices, switches and the type of switching conform to the requirements of Performance Level d and category 3 according to EN ISO 13849-1.
- Depending on the risk situation: the safety gate is additionally safeguarded by means of a locking mechanism that only allows the gate to be opened if the manipulator is safely at a standstill.
- The device for setting the signal for operator safety, e.g. the button for acknowledging the safety gate, is located outside the space limited by the safeguards.



Further information is contained in the corresponding standards and regulations. These also include EN 953.

Other safety equipment

Other safety equipment must be integrated into the system in accordance with the corresponding standards and regulations.

5.4 Safety measures

5.4.1 General safety measures

The industrial robot may only be used in perfect technical condition in accordance with its intended use and only by safety-conscious persons. Operator errors can result in personal injury and damage to property.

It is important to be prepared for possible movements of the industrial robot even after the robot controller has been switched off and locked out. Incorrect installation (e.g. overload) or mechanical defects (e.g. brake defect) can cause the manipulator to sag. If work is to be carried out on a switched-off industrial robot, the manipulator must first be moved into a position in which it is unable to move on its own, whether the payload is mounted or not. If this is not possible, the manipulator must be secured by appropriate means.



DANGER In the absence of operational safety functions and safeguards, the industrial robot can cause personal injury or material damage. If safety functions or safeguards are dismantled or deactivated, the industrial robot may not be operated.



WARNING Standing underneath the robot arm can cause death or serious injuries. Especially if the industrial robot is moving objects that can become detached (e.g. from a gripper). For this reason, standing underneath the robot arm is prohibited!

smartPAD

The user must ensure that the industrial robot is only operated with the smartPAD by authorized persons.

If more than one smartPAD is used in the overall system, it must be ensured that each smartPAD is unambiguously assigned to the corresponding industrial robot. It must be ensured that 2 smartPADs are not interchanged.

The smartPAD can be configured as unpluggable.



WARNING If the smartPAD is disconnected, the system can no longer be switched off by means of the EMERGENCY STOP device on the smartPAD. If the smartPAD is configured as unpluggable, at least one external EMERGENCY STOP device must be installed that is accessible at all times. Failure to observe this can lead to death, injury or property damage.



WARNING The operator must ensure that disconnected smartPADs are immediately removed from the system and stored out of sight and reach of personnel working on the industrial robot. This prevents operational and non-operational EMERGENCY STOP devices from becoming interchanged.
Failure to observe this can lead to death, injury or property damage.

Modifications

After modifications to the industrial robot, checks must be carried out to ensure the required safety level. The valid national or regional work safety regulations must be observed for this check. The correct functioning of all safety functions must also be tested.

New or modified programs must always be tested first in Manual Reduced Velocity mode (T1).

After modifications to the industrial robot, existing programs must always be tested first in Manual Reduced Velocity mode (T1). This applies to all components of the industrial robot and includes modifications to the software and configuration settings.

The robot may not be connected and disconnected when the robot controller is running.

Faults

The following tasks must be carried out in the case of faults in the industrial robot:

- Switch off the robot controller and secure it (e.g. with a padlock) to prevent unauthorized persons from switching it on again.
- Indicate the fault by means of a label with a corresponding warning (tag-out).
- Keep a record of the faults.
- Eliminate the fault and carry out a function test.

5.4.2 Transportation

Manipulator

The prescribed transport position of the manipulator must be observed. Transportation must be carried out in accordance with the operating instructions or assembly instructions of the robot.

Avoid vibrations and impacts during transportation in order to prevent damage to the manipulator.

Robot controller

The prescribed transport position of the robot controller must be observed. Transportation must be carried out in accordance with the operating instructions or assembly instructions of the robot controller.

Avoid vibrations and impacts during transportation in order to prevent damage to the robot controller.

5.4.3 Start-up and recommissioning

Before starting up systems and devices for the first time, a check must be carried out to ensure that the systems and devices are complete and operational, that they can be operated safely and that any damage is detected.

The valid national or regional work safety regulations must be observed for this check. The correct functioning of all safety functions must also be tested.



Prior to start-up, the passwords for the user groups must be modified in the project settings and transferred to the robot controller in an installation procedure. The passwords must only be communicated to authorized personnel.



The robot controller is preconfigured for the specific industrial robot. If cables are interchanged, the manipulator may receive incorrect data and can thus cause personal injury or material damage. If a system consists of more than one manipulator, always connect the connecting cables to the manipulators and their corresponding robot controllers.



If additional components (e.g. cables), which are not part of the scope of supply of KUKA Roboter GmbH, are integrated into the industrial robot, the user is responsible for ensuring that these components do not adversely affect or disable safety functions.



If the internal cabinet temperature of the robot controller differs greatly from the ambient temperature, condensation can form, which may cause damage to the electrical components. Do not put the robot controller into operation until the internal temperature of the cabinet has adjusted to the ambient temperature.

Function test

The following tests must be carried out before start-up and recommissioning:

General test:

It must be ensured that:

- The industrial robot is correctly installed and fastened in accordance with the specifications in the documentation.
- There are no foreign bodies or loose parts on the industrial robot.
- All required safety equipment is correctly installed and operational.
- The power supply ratings of the industrial robot correspond to the local supply voltage and mains type.
- The ground conductor and the equipotential bonding cable are sufficiently rated and correctly connected.
- The connecting cables are correctly connected and the connectors are locked.

Test of the safety functions:

A function test must be carried out for all the safety-oriented functions to ensure that they are working correctly:

Test of the safety-relevant mechanical and electromechanical components:

The following tests must be performed prior to start-up and at least once every 12 months unless otherwise determined in accordance with a workplace risk assessment:

- Press the EMERGENCY STOP device on the smartPAD. A message must be displayed on the smartPAD indicating that the EMERGENCY STOP has been actuated. At the same time, no error message may be displayed about the EMERGENCY STOP device.
- For all 3 enabling switches on the smartPAD and for the enabling switch on the media flange Touch (if present)
Move the robot in Test mode and release the enabling switch. The robot motion must be stopped. At the same time, no error message may be dis-

played about the enabling device. If the state of the enabling switch is configured at an output, the test can also be performed via the output.

- For all 3 enabling switches on the smartPAD and for the enabling switch on the media flange Touch (if present)
Move the robot in Test mode and press the enabling switch down fully. The robot motion must be stopped. At the same time, no error message may be displayed about the enabling device. If the state of the enabling switch is configured at an output, the test can also be performed via the output.
- Turn the keyswitch on the smartPAD to the right and then back again. There must be no error message displayed on the smartPAD.
- Test the switch-off capability of the safe inputs by switching the robot controller off and then on again. After it is switched on, no error message for a safe output may be displayed.



In the case of incomplete start-up of the system, additional substitute measures for minimizing risk must be taken and documented, e.g. installation of a safety fence, attachment of a warning sign, locking of the main switch. Start-up is incomplete, for example, if not all safety functions have yet been implemented, or if a function test of the safety functions has not yet been carried out.

Test of the functional capability of the brakes:

For the KUKA LBR iiwa (all variants) a brake test is available which can be used to check whether the brakes on all axes apply sufficient braking torque.

Unless otherwise determined by a risk assessment, the brake test must be performed regularly:

- The brake test must be carried out for each axis during start-up and re-commissioning of the industrial robot.
- The brake test must be performed daily during operation.

The user can carry out a risk assessment to determine whether the brake test is required for the specific application and, if so, how often it is to be performed.

5.4.4 Manual mode

Manual mode is the mode for setup work. Setup work is all the tasks that have to be carried out on the industrial robot to enable automatic operation. Setup work includes:

- Jog mode
- Teaching
- Program verification

The following must be taken into consideration in manual mode:

- New or modified programs must always be tested first in Manual Reduced Velocity mode (T1).
- The manipulator and its tooling must never touch or project beyond the safety fence.
- Workpieces, tooling and other objects must not become jammed as a result of the industrial robot motion, nor must they lead to short-circuits or be liable to fall off.
- All setup work must be carried out, where possible, from outside the safeguarded area.

If the setup work has to be carried out inside the safeguarded area, the following must be taken into consideration:

In Manual Reduced Velocity mode (T1):

- If it can be avoided, there must be no other persons inside the safeguarded area.

If it is necessary for there to be several persons inside the safeguarded area, the following must be observed:

- Each person must have an enabling device.
- All persons must have an unimpeded view of the industrial robot.
- Eye-contact between all persons must be possible at all times.
- The operator must be so positioned that he can see into the danger area and get out of harm's way.

In Manual High Velocity mode (T2):

- This mode may only be used if the application requires a test at a velocity higher than Manual Reduced Velocity.
- Teaching is not permissible in this operating mode.
- Before commencing the test, the operator must ensure that the enabling devices are operational.
- There must be no-one present inside the safeguarded area. It is the responsibility of the operator to ensure this.

5.4.5 Automatic mode

Automatic mode is only permissible in compliance with the following safety measures:

- All safety equipment and safeguards are present and operational.
- There are no persons in the system, or the requirements for collaborative operation in accordance with EN ISO 10218 have been met.
- The defined working procedures are adhered to.

If the manipulator comes to a standstill for no apparent reason, the danger zone must not be entered until an EMERGENCY STOP has been triggered.

5.4.6 Maintenance and repair

After maintenance and repair work, checks must be carried out to ensure the required safety level. The valid national or regional work safety regulations must be observed for this check. The correct functioning of all safety functions must also be tested.

The purpose of maintenance and repair work is to ensure that the system is kept operational or, in the event of a fault, to return the system to an operational state. Repair work includes troubleshooting in addition to the actual repair itself.

The following safety measures must be carried out when working on the industrial robot:

- Carry out work outside the danger zone. If work inside the danger zone is necessary, the user must define additional safety measures to ensure the safe protection of personnel.
- Switch off the industrial robot and secure it (e.g. with a padlock) to prevent it from being switched on again. If it is necessary to carry out work with the robot controller switched on, the user must define additional safety measures to ensure the safe protection of personnel.
- If it is necessary to carry out work with the robot controller switched on, this may only be done in operating mode T1.

- Label the system with a sign indicating that work is in progress. This sign must remain in place, even during temporary interruptions to the work.
- The EMERGENCY STOP devices must remain active. If safety functions or safeguards are deactivated during maintenance or repair work, they must be reactivated immediately after the work is completed.



Before work is commenced on live parts of the robot system, the main switch must be turned off and secured against being switched on again. The system must then be checked to ensure that it is deenergized. It is not sufficient, before commencing work on live parts, to execute an EMERGENCY STOP or a safety stop, or to switch off the drives, as this does not disconnect the robot system from the mains power supply. Parts remain energized. Death or severe injuries may result.

Faulty components must be replaced using new components with the same article numbers or equivalent components approved by KUKA Roboter GmbH for this purpose.

Cleaning and preventive maintenance work is to be carried out in accordance with the operating instructions.

Robot controller

Even when the robot controller is switched off, parts connected to peripheral devices may still carry voltage. The external power sources must therefore be switched off if work is to be carried out on the robot controller.

The ESD regulations must be adhered to when working on components in the robot controller.

Voltages in excess of 60 V can be present in various components for several minutes after the robot controller has been switched off! To prevent life-threatening injuries, no work may be carried out on the industrial robot in this time.

Water and dust must be prevented from entering the robot controller.

5.4.7 Decommissioning, storage and disposal

The industrial robot must be decommissioned, stored and disposed of in accordance with the applicable national laws, regulations and standards.

5.4.8 Safety measures for “single point of control”

Overview

If certain components in the industrial robot are operated, safety measures must be taken to ensure complete implementation of the principle of “single point of control” (SPOC).

Components:

- Tools for configuration of bus systems with online functionality



The implementation of additional safety measures may be required. This must be clarified for each specific application; this is the responsibility of the user of the system.

Since only the system integrator knows the safe states of actuators in the periphery of the robot controller, it is his task to set these actuators to a safe state.

T1, T2, CRR

In modes T1, T2 and CRR, a robot motion can only be initiated if an enabling switch is held down.

Tools for configuration of bus systems

If these components have an online functionality, they can be used with write access to modify programs, outputs or other parameters of the robot controller, without this being noticed by any persons located inside the system.

- KUKA Sunrise.Workbench
- WorkVisual from KUKA
- Tools from other manufacturers

Safety measure:

- In the test modes, programs, outputs or other parameters of the robot controller must not be modified using these components.

5.5 Applied norms and directives

Name	Definition	Edition
2006/42/EC	Machinery Directive: Directive 2006/42/EC of the European Parliament and of the Council of 17 May 2006 on machinery, and amending Directive 95/16/EC (recast)	2006
2014/30/EU	EMC Directive: Directive 2014/30/EC of the European Parliament and of the Council of 26 February 2014 on the approximation of the laws of the Member States concerning electromagnetic compatibility	2014
EN ISO 13850	Safety of machinery: Emergency stop - Principles for design	2008
EN ISO 13849-1	Safety of machinery: Safety-related parts of control systems - Part 1: General principles of design	2008
EN ISO 13849-2	Safety of machinery: Safety-related parts of control systems - Part 2: Validation	2012
EN ISO 12100	Safety of machinery: General principles of design, risk assessment and risk reduction	2010
EN ISO 10218-1	Industrial robots – Safety requirements Part 1: Robot Note: Content equivalent to ANSI/RIA R.15.06-2012, Part 1	2011
EN 614-1 + A1	Safety of machinery: Ergonomic design principles - Part 1: Terms and general principles	2009
EN 61000-6-2	Electromagnetic compatibility (EMC): Part 6-2: Generic standards; Immunity for industrial environments	2005

EN 61000-6-4 + A1	Electromagnetic compatibility (EMC): Part 6-4: Generic standards; Emission standard for industrial environments	2011
EN 60204-1 + A1	Safety of machinery: Electrical equipment of machines - Part 1: General requirements	2009
EN 62061 + A1	Safety of machinery: Functional safety of safety-related electrical, electronic and programmable electronic control systems	2012

6 Planning

6.1 Mounting variant

The following mounting variants are available for installing the robot:

- Machine frame mounting with centering (>>> 6.1.1 "Machine frame mounting with centering" Page 65)

6.1.1 Machine frame mounting with centering

The machine frame mounting assembly is used when the robot is fastened on a steel structure, a booster frame (pedestal) or a KUKA linear unit. This assembly is also used if the robot is installed on the ceiling. It must be ensured that the substructure is able to withstand safely the forces occurring during operation (foundation loads). The following diagram contains all the necessary information that must be observed when preparing the mounting surface.

The machine frame mounting assembly consists of:

- Locating pins
- Allen screws

Dimensioned drawing

The following illustrations provide all the necessary information on machine frame mounting, together with the required foundation data.

- LBR iiwa 7 R800

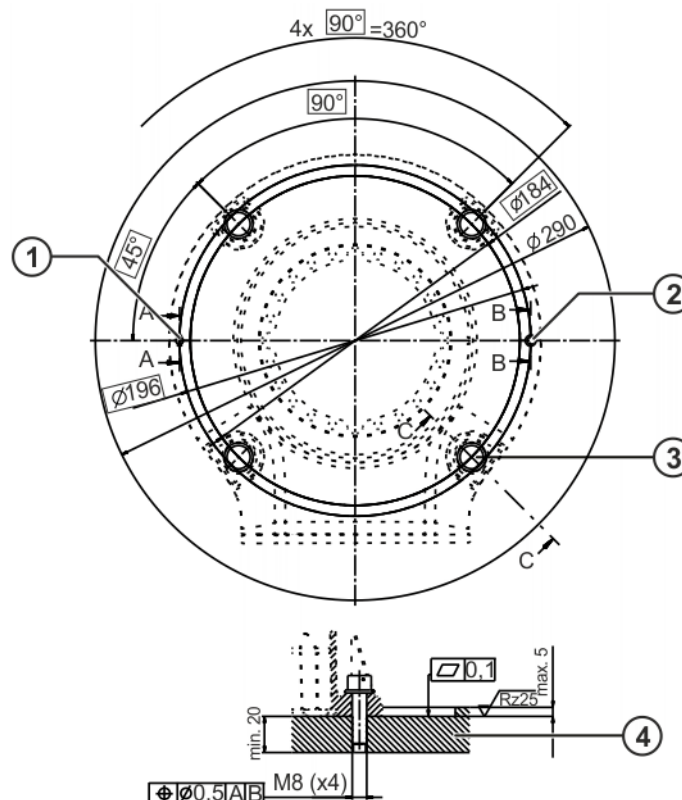

Fig. 6-1: Machine frame mounting, dimensioned drawing LBR iiwa 7 R800

- 1 Flat-sided locating pin, 6x12
- 2 Cylindrical locating pin, 6x12

- 3 M8x30-8.8 Allen screw (4x) with washer
- 4 Steel structure

■ LBR iiwa 14 R820

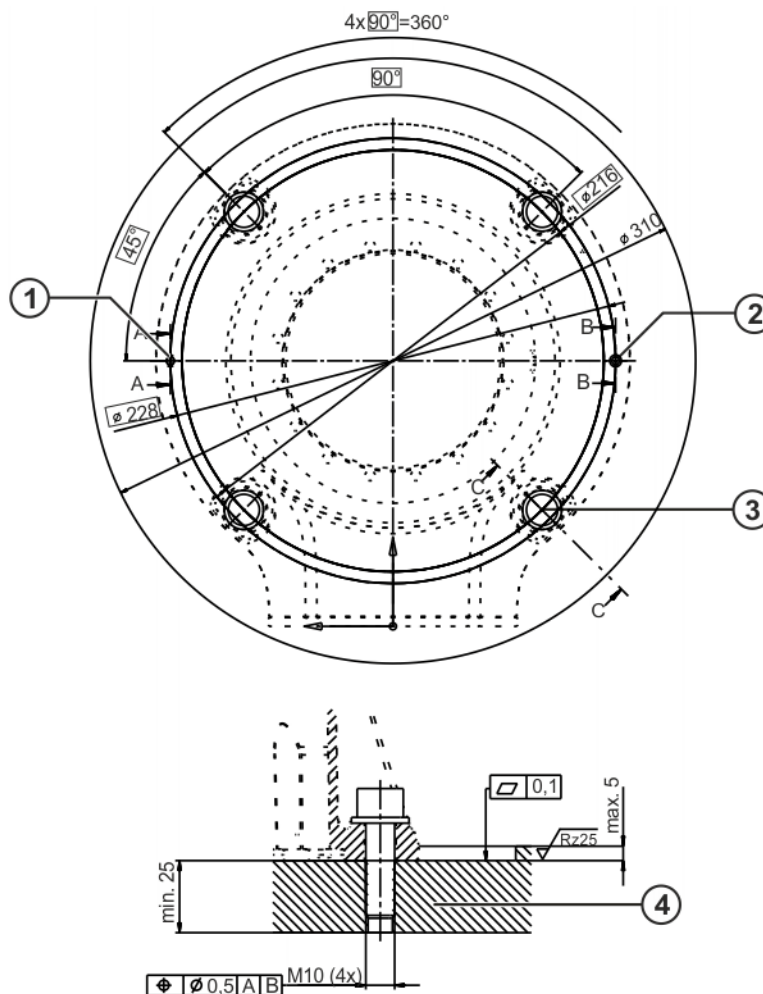

Fig. 6-2: Machine frame mounting, dimensioned drawing LBR iiwa 14 R820

- 1 Flat-sided locating pin, 6x12
- 2 Cylindrical locating pin, 6x12
- 3 M10x35-8.8 Allen screw (4x) with washer
- 4 Steel structure

6.2 Connecting cables and interfaces

Connecting cables

The connecting cables comprise all the cables for transferring energy and signals between the robot and the robot controller. They are connected on the robot side at interface A1. The set of connecting cables comprises:

- Data cable with power supply

Depending on the specification of the robot, various connecting cables are used. The standard cable length is 4 m. Cable lengths of 1 m, 3 m, 4 m, 7 m and 15 m are available as an option. The maximum length of the connecting cables must not exceed 15 m. If the robot is operated on a linear unit which has its own energy supply chain these cables must also be taken into account.

The following points must be observed when planning and routing the connecting cables:

- The bending radius for fixed routing must not be less than 45 mm for data cables.
- Protect cables against exposure to mechanical stress.
- Route the cables without mechanical stress – no tensile forces on the connectors
- Cables are only to be installed indoors.
- Observe permissible temperature range (fixed installation) of 263 K (-10 °C) to 343 K (+70 °C).
- Route the connecting cable in a metal duct; if necessary, additional measures must be taken to ensure electromagnetic compatibility (EMC).

7 Transportation

7.1 Transportation

It must be ensured that the robot is stable while it is being transported. The robot must remain in its transport position until it has been fastened in position. Before the robot is transported, the tooling must be dismantled and the connecting cables must be unplugged.

On delivery of the robot, the transport safeguards such as nails or screws must be removed before installation. If the robot is installed before transportation, it may be jammed tight by rust or glue on contact surfaces.

The following variants are available for transporting the robot:

- Transport packaging
(>>> 7.1.1 "Transportation with transport packaging" Page 69)
- Transport box (optional)
(>>> 7.1.2 "Transportation with transport box (optional)" Page 70)

WARNING Use of unsuitable handling equipment may result in damage to the robot or injury to persons. Only use authorized handling equipment with a sufficient load-bearing capacity. Only transport the robot in the manner specified here.

NOTICE The robot may only be transported in the transport position and in the transport container provided.

i For removal, the robot must be lifted between axes A2 and A3 and between A4 and A5. This applies to both transportation variants.

7.1.1 Transportation with transport packaging

Transport position

The robot must be in the transport position before it can be transported. The robot is in the transport position when the axes are in the following positions:

A1 (J1)	A2 (J2)	A3 (J4)	A4 (J5)	A5 (J6)	A6 (J7)	A7 (J8)
0°	25°	0°	90°	0°	0°	0°

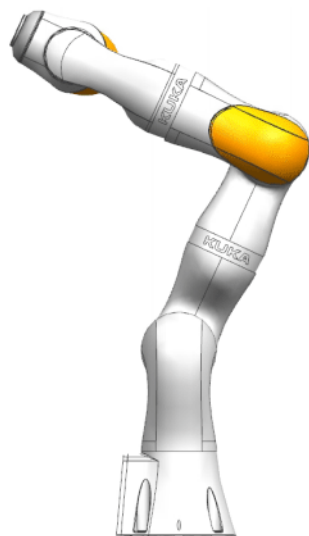

Fig. 7-1: Robot in transport position

Transport dimensions

Transport the robot in the transport packaging provided that has the following outer dimensions:

- Length: 1180 mm
- Width: 780 mm
- Height: 560 mm

The transport dimensions are identical for both variants.

7.1.2 Transportation with transport box (optional)

Transport position

The robot must be in the transport position before it can be transported (>>> Fig. 7-2). The robot is in the transport position when the axes are in the following positions:

A1 (J1)	A2 (J2)	A3 (J4)	A4 (J5)	A5 (J6)	A6 (J7)	A7 (J8)
0	0	0	0	0	0	0°

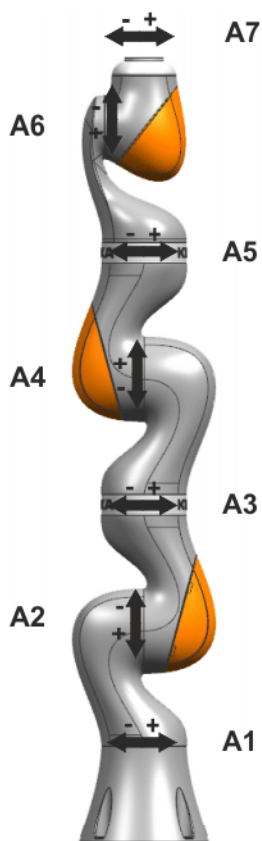

Fig. 7-2: Robot axes

Transport dimensions

Transport the robot in the transport box provided that has the following outer dimensions:

- Length: 1450 mm
- Width: 480 mm
- Height: 340 mm

The transport dimensions are identical for both variants.

8 KUKA Service

8.1 Requesting support

Introduction	This documentation provides information on operation and operator control, and provides assistance with troubleshooting. For further assistance, please contact your local KUKA subsidiary.
Information	<p>The following information is required for processing a support request:</p> <ul style="list-style-type: none"> ■ Description of the problem, including information about the duration and frequency of the fault ■ As comprehensive information as possible about the hardware and software components of the overall system <p>The following list gives an indication of the information which is relevant in many cases:</p> <ul style="list-style-type: none"> ■ Model and serial number of the kinematic system, e.g. the manipulator ■ Model and serial number of the controller ■ Model and serial number of the energy supply system ■ Designation and version of the system software ■ Designations and versions of other software components or modifications ■ Diagnostic package KRCDiag <p>Additionally for KUKA Sunrise: Existing projects including applications For versions of KUKA System Software older than V8: Archive of the software (KRCDiag is not yet available here.)</p> <ul style="list-style-type: none"> ■ Application used ■ External axes used

8.2 KUKA Customer Support

Availability	KUKA Customer Support is available in many countries. Please do not hesitate to contact us if you have any questions.
Argentina	<p>Ruben Costantini S.A. (Agency) Luis Angel Huergo 13 20 Parque Industrial 2400 San Francisco (CBA) Argentina Tel. +54 3564 421033 Fax +54 3564 428877 ventas@costantini-sa.com</p>
Australia	<p>KUKA Robotics Australia Pty Ltd 45 Fennell Street Port Melbourne VIC 3207 Australia Tel. +61 3 9939 9656 info@kuka-robotics.com.au www.kuka-robotics.com.au</p>

Belgium	KUKA Automatisering + Robots N.V. Centrum Zuid 1031 3530 Houthalen Belgium Tel. +32 11 516160 Fax +32 11 526794 info@kuka.be www.kuka.be
Brazil	KUKA Roboter do Brasil Ltda. Travessa Claudio Armando, nº 171 Bloco 5 - Galpões 51/52 Bairro Assunção CEP 09861-7630 São Bernardo do Campo - SP Brazil Tel. +55 11 4942-8299 Fax +55 11 2201-7883 info@kuka-roboter.com.br www.kuka-roboter.com.br
Chile	Robotec S.A. (Agency) Santiago de Chile Chile Tel. +56 2 331-5951 Fax +56 2 331-5952 robotec@robotec.cl www.robotec.cl
China	KUKA Robotics China Co., Ltd. No. 889 Kungang Road Xiaokunshan Town Songjiang District 201614 Shanghai P. R. China Tel. +86 21 5707 2688 Fax +86 21 5707 2603 info@kuka-robotics.cn www.kuka-robotics.com
Germany	KUKA Roboter GmbH Zugspitzstr. 140 86165 Augsburg Germany Tel. +49 821 797-4000 Fax +49 821 797-4040 info@kuka.com www.kuka-robotics.com

France KUKA Automatismes + Robotique SAS
Techvallée
6, Avenue du Parc
91140 Villebon S/Yvette
France
Tel. +33 1 6931660-0
Fax +33 1 6931660-1
commercial@kuka.fr
www.kuka.fr

India KUKA Robotics India Pvt. Ltd.
Office Number-7, German Centre,
Level 12, Building No. - 9B
DLF Cyber City Phase III
122 002 Gurgaon
Haryana
India
Tel. +91 124 4635774
Fax +91 124 4635773
info@kuka.in
www.kuka.in

Italy KUKA Roboter Italia S.p.A.
Via Pavia 9/a - int.6
10098 Rivoli (TO)
Italy
Tel. +39 011 959-5013
Fax +39 011 959-5141
kuka@kuka.it
www.kuka.it

Japan KUKA Robotics Japan K.K.
YBP Technical Center
134 Godo-cho, Hodogaya-ku
Yokohama, Kanagawa
240 0005
Japan
Tel. +81 45 744 7691
Fax +81 45 744 7696
info@kuka.co.jp

Canada KUKA Robotics Canada Ltd.
6710 Maritz Drive - Unit 4
Mississauga
L5W 0A1
Ontario
Canada
Tel. +1 905 670-8600
Fax +1 905 670-8604
info@kukarobotics.com
www.kuka-robotics.com/canada

Korea	KUKA Robotics Korea Co. Ltd. RIT Center 306, Gyeonggi Technopark 1271-11 Sa 3-dong, Sangnok-gu Ansan City, Gyeonggi Do 426-901 Korea Tel. +82 31 501-1451 Fax +82 31 501-1461 info@kukakorea.com
Malaysia	KUKA Robot Automation (M) Sdn Bhd South East Asia Regional Office No. 7, Jalan TPP 6/6 Taman Perindustrian Puchong 47100 Puchong Selangor Malaysia Tel. +60 (03) 8063-1792 Fax +60 (03) 8060-7386 info@kuka.com.my
Mexico	KUKA de México S. de R.L. de C.V. Progreso #8 Col. Centro Industrial Puente de Vigas Tlalnepantla de Baz 54020 Estado de México Mexico Tel. +52 55 5203-8407 Fax +52 55 5203-8148 info@kuka.com.mx www.kuka-robotics.com/mexico
Norway	KUKA Sveiseanlegg + Roboter Sentrumsvegen 5 2867 Hov Norway Tel. +47 61 18 91 30 Fax +47 61 18 62 00 info@kuka.no
Austria	KUKA Roboter CEE GmbH Gruberstraße 2-4 4020 Linz Austria Tel. +43 7 32 78 47 52 Fax +43 7 32 79 38 80 office@kuka-roboter.at www.kuka.at

Poland KUKA Roboter Austria GmbH
Spółka z ograniczoną odpowiedzialnością
Oddział w Polsce
Ul. Porcelanowa 10
40-246 Katowice
Poland
Tel. +48 327 30 32 13 or -14
Fax +48 327 30 32 26
ServicePL@kuka-roboter.de

Portugal KUKA Robots IBÉRICA, S.A.
Rua do Alto da Guerra n° 50
Armazém 04
2910 011 Setúbal
Portugal
Tel. +351 265 729 780
Fax +351 265 729 782
info.portugal@kukapt.com
www.kuka.com

Russia KUKA Robotics RUS
Werbnaja ul. 8A
107143 Moskau
Russia
Tel. +7 495 781-31-20
Fax +7 495 781-31-19
info@kuka-robotics.ru
www.kuka-robotics.ru

Sweden KUKA Svetsanläggningar + Robotar AB
A. Odhners gata 15
421 30 Västra Frölunda
Sweden
Tel. +46 31 7266-200
Fax +46 31 7266-201
info@kuka.se

Switzerland KUKA Roboter Schweiz AG
Industriestr. 9
5432 Neuenhof
Switzerland
Tel. +41 44 74490-90
Fax +41 44 74490-91
info@kuka-roboter.ch
www.kuka-roboter.ch

Spain	KUKA Robots IBÉRICA, S.A. Pol. Industrial Torrent de la Pastera Carrer del Bages s/n 08800 Vilanova i la Geltrú (Barcelona) Spain Tel. +34 93 8142-353 Fax +34 93 8142-950 comercial@kukarob.es www.kuka.es
South Africa	Jendamark Automation LTD (Agency) 76a York Road North End 6000 Port Elizabeth South Africa Tel. +27 41 391 4700 Fax +27 41 373 3869 www.jendamark.co.za
Taiwan	KUKA Robot Automation Taiwan Co., Ltd. No. 249 Pujong Road Jungli City, Taoyuan County 320 Taiwan, R. O. C. Tel. +886 3 4331988 Fax +886 3 4331948 info@kuka.com.tw www.kuka.com.tw
Thailand	KUKA Robot Automation (M)SdnBhd Thailand Office c/o Maccall System Co. Ltd. 49/9-10 Soi Kingkaew 30 Kingkaew Road Tt. Rachatheva, A. Bangpli Samutprakarn 10540 Thailand Tel. +66 2 7502737 Fax +66 2 6612355 atika@ji-net.com www.kuka-roboter.de
Czech Republic	KUKA Roboter Austria GmbH Organisation Tschechien und Slowakei Sezemická 2757/2 193 00 Praha Horní Počernice Czech Republic Tel. +420 22 62 12 27 2 Fax +420 22 62 12 27 0 support@kuka.cz

Hungary KUKA Robotics Hungaria Kft.
Fö út 140
2335 Taksony
Hungary
Tel. +36 24 501609
Fax +36 24 477031
info@kuka-robotics.hu

USA KUKA Robotics Corporation
51870 Shelby Parkway
Shelby Township
48315-1787
Michigan
USA
Tel. +1 866 873-5852
Fax +1 866 329-5852
info@kukarobotics.com
www.kukarobotics.com

UK KUKA Robotics UK Ltd
Great Western Street
Wednesbury West Midlands
WS10 7LL
UK
Tel. +44 121 505 9970
Fax +44 121 505 6589
service@kuka-robotics.co.uk
www.kuka-robotics.co.uk

Index

Numbers

2006/42/EC 63

2014/30/EU 63

95/16/EC 63

A

Accessories 9, 45

Angle of rotation 24

ANSI/RIA R.15.06-2012 63

Applied norms and directives 63

AUT 47

Automatic 47

Automatic mode 61

Axis data, LBR iiwa 14 R820 17

Axis data, LBR iiwa 7 R800 12

Axis range 47

B

Basic data, LBR iiwa 14 R820 17

Basic data, LBR iiwa 7 R800 11

Brake defect 57

Braking distance 47

C

CE mark 46

Cleaning work 62

Connecting cables 9, 45

Connecting cables and interfaces 66

CRR 47

D

Danger zone 47

Declaration of conformity 46

Declaration of incorporation 45, 46

Decommissioning 62

Disposal 62

Documentation, industrial robot 5

E

EC declaration of conformity 46

Electromagnetic compatibility (EMC) 63, 64

EMC Directive 46, 63

EMERGENCY STOP device 50, 51, 52

EMERGENCY STOP, external 50, 52

EN 60204-1 + A1 64

EN 61000-6-2 63

EN 61000-6-4 + A1 64

EN 614-1 + A1 63

EN 62061 + A1 64

EN ISO 10218-1 63

EN ISO 12100 63

EN ISO 13849-1 63

EN ISO 13849-2 63

EN ISO 13850 63

Enabling device 50, 51

Enabling device, external 50, 53

Enabling switches 51

F

Faults 58

Foundation data, LBR iiwa 14 R820 21

Foundation data, LBR iiwa 7 R800 15

Function test 59

G

General information 23

General safety measures 57

H

Hand-held control panel 9, 45

Handling equipment 69

I

Industrial robot 45

Intended use 7, 45

Introduction 5

J

Jog mode 56

K

KCP 6

KCP, KUKA Control Panel 24

KUKA Customer Support 71

KUKA smartPAD 48

KUKA Sunrise Cabinet 9

L

Labeling 56

LBR iiwa 5

Liability 45

Low Voltage Directive 46

M

Machine frame mounting with centering 65

Machinery Directive 46, 63

Maintenance 61

Manipulator 6, 9, 45, 48, 50

Manual mode 60

Mode selection 54

Monitoring, physical safeguards 52

Mounting variant 65

N

Non-safety-oriented functions 54

O

Operator 47, 49

Operator safety 50, 52

Options 9, 45

Overload 57

Overview 9

Overview of the robot system 9

P

Panic position 51

Payloads, LBR iiwa 14 R820 19
 Payloads, LBR iiwa 7 R800 13
 Performance Level 46
 Personnel 48
 Planning 65
 Plant integrator 48
 Plates and labels 22
 Preventive maintenance work 62
 Product description 9
 Program override, motion velocity 24
 Protective equipment 56
 Purpose 7

R

Reaction distance 47
 Repair 61
 Robot controller 45

S

Safe operational stop, external 50, 53
 Safeguards, external 56
 Safety 45
 Safety functions 46
 Safety instructions 5
 Safety of machinery 63, 64
 Safety stop 48
 Safety stop 0 48
 Safety stop 1 48
 Safety stop 1 (path-maintaining) 48
 Safety stop, external 50, 52
 Safety zone 48, 49, 50
 Safety-oriented functions 50
 Safety-oriented stop reactions 53
 Safety, legal framework 45
 Service life 47
 Service, KUKA Roboter GmbH 71
 Single point of control 62
 smartPAD 6, 48, 57
 Software 9, 45
 Software limit switches 55
 SPOC 62
 Start-up/Recommissioning 58
 STOP 0 24
 STOP 1 24
 Stop category 0 48
 Stop category 1 48
 Stop category 1 (path-maintaining) 48
 Stop reactions, safety-oriented 53
 Stop signal 23
 Stopping distance 23, 47, 50
 Stopping distances 23
 Stopping distances for LBR iiwa 14 R820 34
 Stopping distances for LBR iiwa 7 R800 26
 Stopping distances for STOP 0, axis 1 to axis 4
 26, 35
 Stopping distances for STOP 1, axis 1 27, 36
 Stopping distances for STOP 1, axis 2 29, 38
 Stopping distances for STOP 1, axis 3 31, 40
 Stopping distances for STOP 1, axis 4 33, 42
 Stopping time 24
 Stopping times 23

Stopping times for LBR iiwa 14 R820 34
 Stopping times for LBR iiwa 7 R800 26
 Stopping times for STOP 0, axis 1 to axis 4 26,
 35
 Stopping times for STOP 1, axis 1 27, 36
 Stopping times for STOP 1, axis 2 29, 38
 Stopping times for STOP 1, axis 3 31, 40
 Stopping times for STOP 1, axis 4 33, 42
 Storage 62
 Supplementary load 15, 21
 Support request 71
 System integrator 46, 48, 49

T

T1 48
 T2 48
 Technical data 11
 Technical data, LBR iiwa 14 R820 17
 Technical data, LBR iiwa 7 R800 11
 Technical data, overview 11
 Terms used 5, 24
 Terms used, safety 47
 Training 7
 Transport dimensions 70
 Transport position 69, 70
 Transportation 58, 69

U

Use, contrary to intended use 45
 Use, improper 45
 User 47, 49
 Users 7

W

Warnings 5
 Workspace 47, 49, 50

